



**MITSUBISHI  
MOTORS**

# **SMARTPHONE-LINK DISPLAY AUDIO (SDA)**

---

Owner's Manual

Not For Reproduction

## User precautions

It is essential to follow the precautions below when using the system, both in the interest of safety and to prevent material damage. Always comply with the laws of the country in which you are travelling.



### **Precautions when operating the system**

- Operate the controls and read the information on the screen only when road conditions allow.
- Set the volume to a reasonable level so that outside noise can be heard.

### **Precautions regarding navigation**

- Use of the navigation system does not in any way replace the responsibility or vigilance of the driver when driving the vehicle.
- Depending on the geographical area, the map may not have the latest information on new roads. Be alert. In all cases, Road Traffic Regulations and road signs always take precedence over the directions of the navigation system.

### **Precautions concerning driving aids**

These functions are additional driving aids. These functions are not under any circumstances intended to replace the due care and attention of the driver, who should be in control of the vehicle at all times. The driver should always adapt their speed to the traffic conditions, regardless of the system indications.

### **Precautions concerning material damage**

- Do not attempt to dismantle or modify the system to avoid any risk of fire or damage to equipment.
- Contact a representative of the manufacturer in the event of malfunction and for all operations involving disassembly.
- Do not insert foreign objects or a damaged or dirty external storage device (USB key, SD card etc.) into the reader.
- Use an external storage device (USB flash drive, Jack socket etc.) that is compatible with your system.
- Always clean your screen with a microfibre cloth.
- Do not use products containing alcohol and/or spray fluids on the area.



The prior acceptance of the General Conditions of Sale is mandatory before using the system.  
For further information, please contact an approved dealer.



- MITSUBISHI MOTORS CORPORATION and the relevant local MMC affiliate providing services for your region (we, us or our) are the controllers of your personal data that is processed while you're using your vehicle for the following purposes which may include (depending on your model and available services in your country):
  - to supply the connected services to which you subscribed, to improve and optimise your driving experience in particular when planning your trips, to enable you to benefit from a positive driving assistance, to enable control of your car to be operated remotely, to identify the maintenance needs of your vehicle in order to secure its optimal operation, to improve and/or develop the products and services available to you, to optimise the knowledge of the vehicle's usage and to help us to meet the legal and regulatory obligations linked to your vehicle and its usage. Some of those aforementioned services may require knowledge of the geolocation of your vehicle (such as emergency call or trip planning) in compliance with your regional/ national/ local regulations.
  - Your data can be transmitted to the members of our distribution network, our subcontractors and also to third parties, both within and outside your country or region as your regional regulations permit, including public authorities in order to meet our legal or regulatory requirements.
  - Your data may also be transmitted, in a pseudonymised or anonymised form, to other recipients such as our private partners, in order to improve and/or develop their product and services or our public partners for the development of services and intelligent mobility.
  - For more details about the abovementioned list of connected services, partner list, and regional/national/ local privacy notices please visit the Mitsubishi Motors website in your country or region to view the full privacy policy that applies to you and your vehicle.
  - If you use services offered by third parties (eg Google), their terms of use are governed by their own data protection policies.
  - You must inform any other user or purchaser of this vehicle of the conditions under which their personal data is processed as described above.
  - If you refuse the transmission of your data to us, please note that it may deprive you of some or all connected services.
  - You may have the right to exercise applicable privacy rights under your regional/national/local privacy laws. To know more about your privacy rights, please visit the Mitsubishi Motors website in your country or region to see the full privacy policy that applies to you and your vehicle.



### **Protection of your personal data**

Regardless of whether or not you decide to suspend sharing, the vehicle usage data will be forwarded to the manufacturer and the partners/subsidiaries concerned for the following purposes:

- to enable the operation and maintenance of your vehicle;
- improve the life cycle of your vehicle.

The purpose of using this data is not commercial canvassing but rather the continuous improvement of the manufacturer's vehicles and the prevention of problems that may hinder their daily operation.

For more information, please see the data protection policy on the manufacturer's website.



**The description of the models given in this manual is based on the technical specifications at the time of writing.**

**This manual covers all existing functions (standard or optional) for the models described. Whether or not they are fitted depends on the equipment model, options selected and the country where they are sold. The functions described in this manual are subject to future modification due to updates, regulations or technical constraints. This manual may also contain information about functions to be introduced later in the model year. The screens shown in the user manual are not contractual.**

- anywhere in the manual indicates a transfer to a page.

# CONTENTS

<b>General information</b> .....	<b>5</b>	Driving aids .....	74
General description .....	5	Parking aids .....	79
Introduction to the controls .....	9	Reversing camera .....	82
Activating services .....	11	360° Camera .....	84
operating principles .....	15	Drive Mode .....	85
Cleaning .....	18	Ambient lighting .....	88
Switching on, off .....	19	Tyre pressure.....	90
Add, manage widgets .....	20	My driving .....	91
Using voice recognition .....	22	Emergency call .....	94
<b>Navigation</b> .....	<b>28</b>	<b>Settings</b> .....	<b>95</b>
Map .....	28	User settings.....	95
Enter a destination .....	32	System settings .....	99
Navigation settings .....	38	Notifications .....	102
<b>Audio/Multimedia</b> .....	<b>42</b>	Update .....	104
Audio sources .....	42	Operating faults .....	106
Listen to the radio .....	44		
Music .....	48		
Audio settings .....	51		
<b>Phone</b> .....	<b>53</b>		
Pair and connect a phone.....	53		
Call management .....	57		
SMS .....	62		
Phone Settings .....	64		
Wireless charger.....	65		
<b>Apps</b> .....	<b>67</b>		
Android Auto™, CarPlay™ .....	67		
App management .....	71		
Vehicle loaning and relinquishing .....	73		
<b>Vehicle</b> .....	<b>76</b>		

# GENERAL DESCRIPTION

## Screen

**i** For further information on the heating level, please refer to your vehicle user manual.

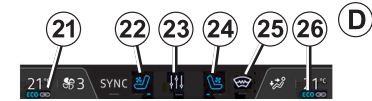
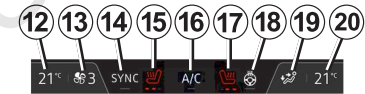
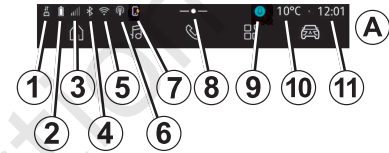
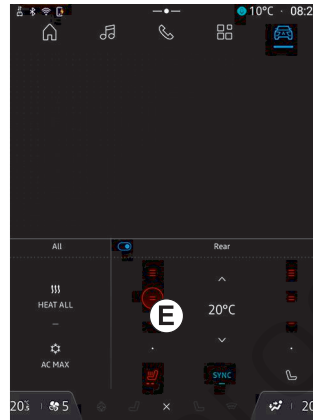
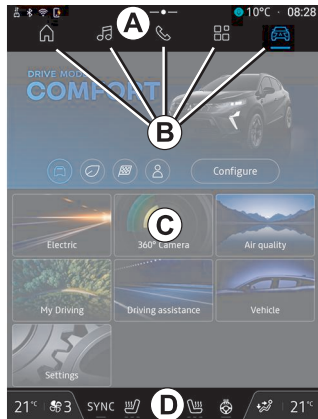

- A.** Access and status bar.
- B.** Access to different Worlds.
- C.** Display area for selected World.
- D.** Heating level bar indicator.
- E.** Heating level settings (depending on equipment).





- 1.** Status of the connection and sharing of data;
- 2.** Phone battery charge level.
- 3.** Phone reception status.
- 4.** Bluetooth® of the activated multimedia system.
- 5.** Multimedia system WIFI status.
- 6.** Access Point activated.
- 7.** Status of the wireless charger.
- 8.** Access to the notification centre.
- 9.** Microphone status and control.
- 10.** Exterior temperature.
- 11.** Time.
- 12.** Driver's heating temperature indicator.

## GENERAL DESCRIPTION

- 13. Ventilation speed indicator.
- 14. Synchronisation control SYNC.
- 15. Heated driver seat control.
- 16. Air conditioning control.
- 17. Heated passenger seat control.
- 18. Heated steering wheel control.
- 19. Passenger compartment air distribution indicator.
- 20. Passenger heating temperature indicator.
- 21. "Synchronisation" indicator SYNC activated.
- 22. Driver's ventilated seat control.
- 23. Access heating level settings **E**.
- 24. Passenger ventilated seat control.
- 25. Heated windscreen control.
- 26. Air conditioning on indicator ECO.

### Menu Screens

Your system is made up of several menus **B** :

- « Navigation »  ;
- « Audio »  ;
- "Phone"  or "Smartphone replication"   ;

– « Applications »  ;

– « Vehicle »  .

**Note:** the availability of menus depends on the equipment.

You can access the various menus at any time from the Worlds bar **B** which is visible and accessible at all times on the active screen.

### "Navigation" Menu

(depending on equipment)



The "Navigation" Menu  , which can be accessed using button **27** , provides access to the navigation sys-

tem. It is possible to display two customisable widgets.

### "Audio" Menu

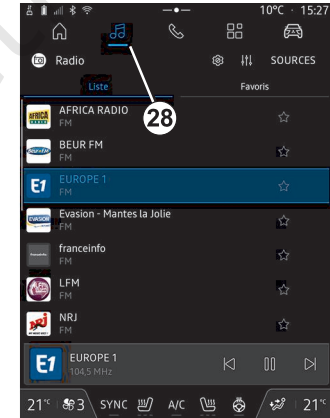

The "Audio" menu  , which can be accessed using button **28** , provides access to the radio and music.

## GENERAL DESCRIPTION

### "Phone" Menu

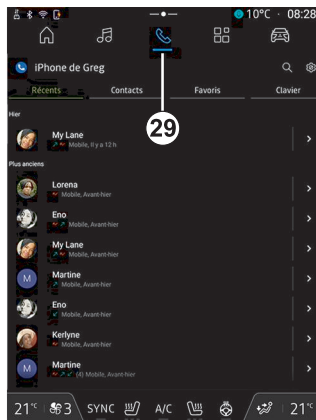

The "Phone" menu  which can be accessed using button **29**, provides access to your calls, phonebook and other telephone functions connected to the multimedia system.

**Note:** the "Phone" menu  icon may change while smartphone replication is in progress  .

### "Applications" Menu

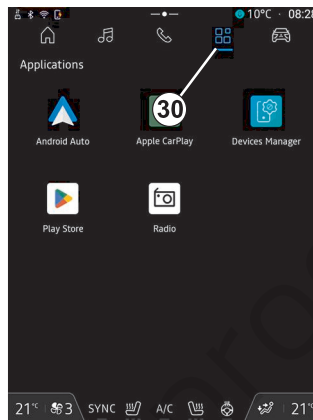

The "Applications" menu  which can be accessed using button **30**, provides access to the applications on the multimedia system and those on "Play Store™" (depending on equipment).

### "Vehicle" Menu

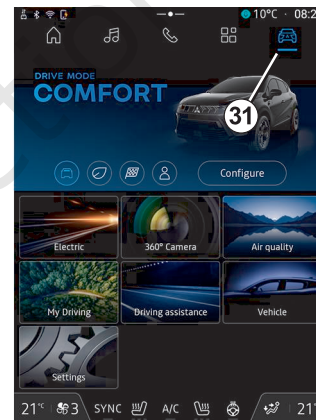

The "Vehicle"  Menu which can be accessed using the button **31**, can be used to manage some vehicle equipment, such as the "Drive Mode", the driving aids, the 360° camera, the My driving, etc. and to adjust some multimedia system settings such as the display, language, etc.

#### **Note:**

- depending on the equipment level, only available functions that can be selected appear on the home screen;
- you can also access the various modes by pressing your vehicle's "Drive Mode" control repeatedly.

## GENERAL DESCRIPTION

1

Please refer to the vehicle user manual for further information.

### Notification centre

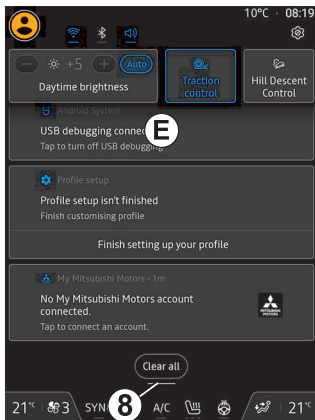

The notification centre **E**, which can be accessed using button **8**, or by quickly swiping the multimedia screen from zone **A** towards the centre of the screen, enables you to access the notifications, "Profile" and some functions. To exit the notification centre, press **8** or swipe up quickly from zone **D** towards the centre of the screen.

# INTRODUCTION TO THE CONTROLS

## Screen controls



	Function
<b>1</b>	Multimedia screen.
<b>2</b>	Volume up.
<b>3</b>	Briefly press: "Radio - Music OFF"/"Radio - Music ON", "Minimal display", "Cleaning screen ", "Stand-by". Press and hold (around five seconds): force the multimedia system to shut down.
<b>4</b>	Volume down.

## Steering column controls

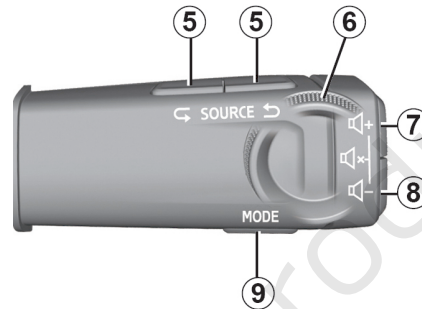

	Function
<b>5</b>	Choosing the audio source.
<b>6</b>	Browse the radio stations or audio tracks and directories (depending on the equipment).
<b>7</b>	Briefly press: – increase the volume of the source currently in use. Press and hold (around 10 seconds): – deactivate the forced muting of audio.

	Function
<b>7</b>	Briefly press: – mute/unmute the radio audio; – pause or play the audio track; – interrupt the voice recognition voice synthesizer.
<b>8</b>	Press and hold (around 10 seconds): – deactivate the forced muting of audio.
<b>8</b>	Briefly press: – decrease the volume of the source currently in use. Press and hold (around 5 seconds): – activate the forced muting of audio.
<b>9</b>	Change the playback mode for the radio stations ("List", "Favourites").

# INTRODUCTION TO THE CONTROLS

1

## Steering wheel control

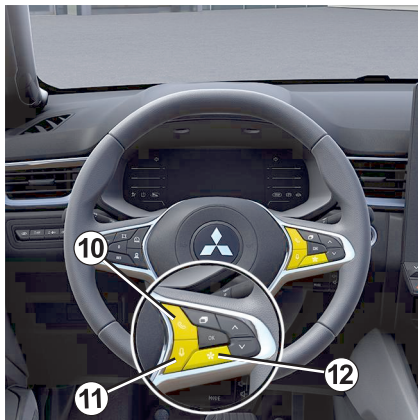

	Function
10	<p>If the telephone is not connected to the multimedia system:</p> <ul style="list-style-type: none"> <li>– access the phone pairing function.</li> </ul> <p>If the telephone is connected to the multimedia system:</p> <ul style="list-style-type: none"> <li>– access the "Phone"  World;</li> <li>– answer/end a call.</li> </ul>
11	<p>Briefly press (vehicles equipped with the navigation system):</p>

	Function
	<ul style="list-style-type: none"> <li>– activate/deactivate voice recognition on your multimedia system.</li> </ul> <p>Press and hold:</p> <ul style="list-style-type: none"> <li>– activate/deactivate your phone's voice recognition (only available when your phone is connected to the multimedia system via phone replication).</li> </ul>
12	<p>Briefly press:</p> <ul style="list-style-type: none"> <li>– select the "Drive Mode" mode.</li> </ul> <p>Press and hold:</p> <ul style="list-style-type: none"> <li>– access the configuration of the "Drive Mode" mode in use.</li> </ul> <p>For more information, refer to the "Drive Mode" section ➔ 85.</p>

# ACTIVATING SERVICES

## Introduction

To use your vehicle's connected services (e.g. Traffic info in real time, on-line search for POI (Points of Interest) they must be first be activated.

Activating the services also enables automatic updating of the system. Refer to the "Update" section ➔ 104.

Once the services have been activated, they will be free to use during a limited period starting from your vehicle delivery date.

The multimedia system offers to configure your profile in a few steps.

### Note:

- the configuration wizard offers assistance each time a profile is created, except for the "Guest" profile;
- the configuration wizard can only be used while the vehicle is stationary.

## Configuration assistant

 The manufacturer shall take all necessary precautions to ensure a level of safety appropriate to the risks, taking into account the applicable rules.

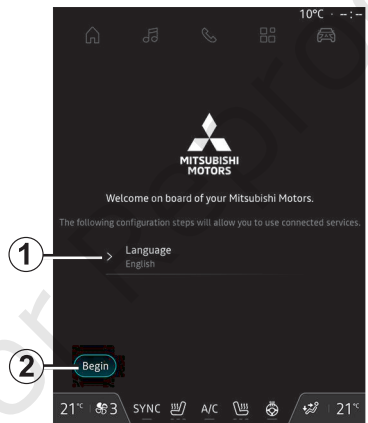

Select the language that you wish to use from the list available at 1, then confirm by pressing 2.

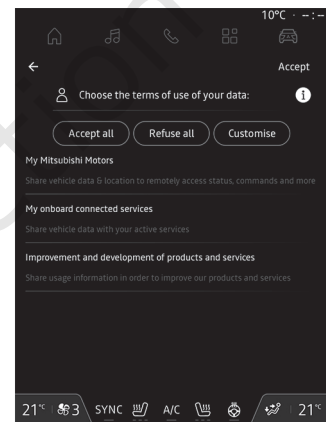

The multimedia system informs you and enables you to control your personal data.

For more information on the various data sharing options, press the "In-

formation" icon .

After reviewing the information provided, confirm your choice by pressing "Confirm" to continue.

Then choose the terms of use of your personal data from the following choices:

- "Accept all" authorises the sharing of your personal data and allows access to all available connected services;
- "Refuse all" refuses the sharing of your personal data and does not allow

# 1

## ACTIVATING SERVICES

access to or operation of connected services (with the exception of regulatory functions related to the safety of the automatic emergency call in the event of an accident);

– "Customise" allows the personalisation of the conditions of use of your personal data by activating/deactivating certain functions related to the following data:

- « My onboard connected services » ;
- "Improvement and development of products and services";
- ...

The multimedia system uses Google® software and services that exchange data with your multimedia system. You are informed of the legal conditions of the Google® services.

You can authorise or reject:

- the use of your location by apps;
- sending usage/diagnostic data. **Note:**
- if you do not want applications to use your vehicle's current position, you will not have access to the navigation Google Maps™;
- for more information about app permissions and privacy, see the sections on "App Management" → 71 and "System Settings" → 99.

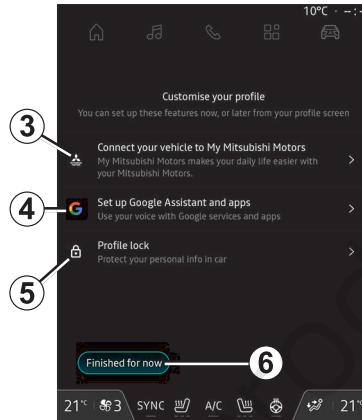

You can customise your profile by configuring the following functions:

- configure "Google Assistant" and the applications 4 ;
- lock the profile 5 .

**Note:** you can suspend the configuration by pressing 6 , then resume it later from the notification centre or your profile. For more information on configuring the profile, please refer to the "User settings" section → 95.

## Configure "Google Assistant" and the applications 4

The multimedia system offers various ways to connect to your account Google®:

- using your Google® account ID (email or phone number, then password);
- depending on your phone model, using a QR Code that can be scanned on the screen of the multimedia system.

Follow the instructions shown on the multimedia system screen.

## Lock the profile 5

In order to safeguard sensitive information and preserve your privacy, we strongly recommend that you protect your personal data. In order to do this, the multimedia system enables you to lock access to your profile using the following methods:

- « Pattern » ;
- « PIN code » ;
- « Password » ;
- "Do not use profile locking".

## ACTIVATING SERVICES

Follow the instructions displayed on the multimedia system screen to complete the configuration.

 To preserve your privacy, including the confidentiality and integrity of your personal data, we strongly recommend that you lock your profile.

### Data collection

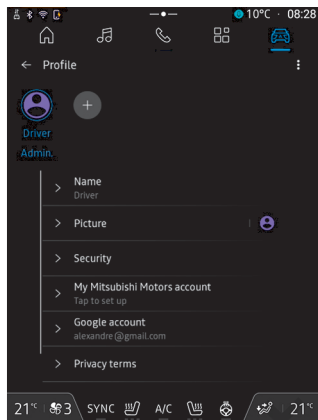

Once your services activation request has been validated, you will still be able to activate/deactivate data collection or to modify the level of data sharing. To choose the terms of use for

your personal data, open the notification centre, select your "Profile", then "Privacy settings".

Then choose from the following levels of data sharing:

- "Accept all": authorise the sharing of your data;
- "Refuse all": refuse the sharing of your data;
- "Customise": authorise the sharing of data that you have selected from the list.

**Note:** if you do not wish to share your data, the services that require your consent may no longer work (except for standard services/functions related to the automatic emergency call in the event of an accident).

### Temporary suspension of data collection

The collection of vehicle data may be temporarily suspended.

To do this, you can pause or modify the level of data collection at any time from your "Profile" available in the Notifications centre: press "Share only data". You can suspend certain data collection by selecting "Refuse all", or suspend certain data collections by selecting "Customise", and then choose those that you want to suspend.

If you refuse data sharing, the services that require your consent may no longer work (except for standard services related to the automatic emergency call in the event of an accident).

 The manufacturer takes all the necessary precautions to ensure that your personal data is processed.

### Data protection

The data from your vehicle is treated by the brand representative and it may be transmitted to our subsidiaries, members of our distribution network as well as out partners, depending on the objective. The data may also be collected by third parties, such as Google®. In this case, their personal data protection rules are applied by authorised distributors and other entities in the brand representative's group. The brand representative's details are available on their website and on the last page of the vehicle user manual.

Your personal data is processed for the following purposes:

- to enable you to update the vehicle automatically.

## ACTIVATING SERVICES

or provide entertainment services in the vehicle;

- to enable vehicle maintenance;
- to provide you with driving or navigation assistance services;
- to improve the driving experience, provide various mobility methods and develop products and services;
- to meet our legal or regulatory obligations.

In accordance with the applicable regulations on the protection of personal data, you can ask to:

- obtain and check the data that the manufacturer holds concerning you;
- correct any inaccurate information;
- remove data concerning you;
- take a copy of your data to reuse it elsewhere;
- oppose the use of your data at any time;
- freeze the use of your data.

From your vehicle's multimedia screen, you can:

- refuse to give your consent to the sharing of your personal data (including location);
- withdraw your consent at any time.

If you decide to suspend the sharing of your personal data, some of the vehicle's functions and/or services supplied by the manufacturer will be stopped as they require your consent.

Regardless of whether or not you decide to suspend sharing, the vehicle usage data will be forwarded to the manufacturer and the partners/subsidiaries concerned for the following purposes:

- to enable the operation and maintenance of your vehicle;
- improve the life cycle of your vehicle.

This data is not used for commercial services but for the continual improvement of the manufacturer's vehicles and to prevent problems that may hinder their daily use.

For more information, the data protection policy is available on the manufacturer's website, for which the address is available in the vehicle user manual.

### Expiry of the services

The services are activated for a limited period. Once this has elapsed, the services cease to work. To get the services back up and running, contact an approved dealer.



The manufacturer shall take all necessary precautions to ensure a level of safety appropriate to the risks, taking into account the applicable rules.

# OPERATING PRINCIPLES

## Multimedia screen



For safety reasons, carry out these operations when the vehicle is stationary.



Some settings have to be modified while the engine is running in order for them to be stored by the multimedia system.

## Navigating a menu

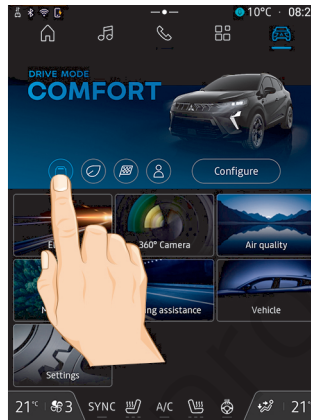

The multimedia screen can be used to access the system functions. Touch the multimedia screen to select one of the menus.

## Gesture interaction

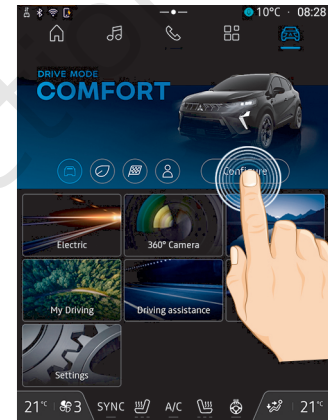

- Briefly press: touch a part of the screen with your finger then immediately take your finger off the screen.
- Press and hold: touch a part of the screen for at least 1.5 second.
- Zoom-in/Zoom-out: bring together two fingers or slide them apart on the screen.

# OPERATING PRINCIPLES

1

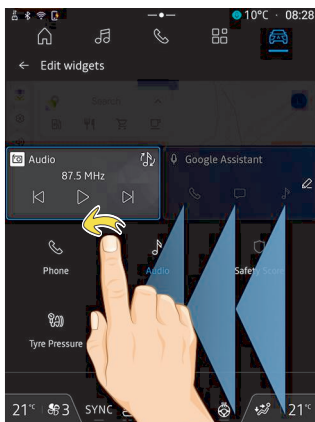

- Swipe: slide your finger quickly:
  - horizontally, from left to right or from right to left;
- or
- vertically, from bottom to top or from top to bottom.

## Introduction to the Menu bar



Your multimedia system includes a Menu bar **A**. The is made up of five Worlds, all of which can be accessed at any times on the multimedia display screen:

- "Home Page" (depending on the equipment): enables you to display four customisable widgets;
- "Navigation" (depending on equipment): includes all the satellite guidance functions, road maps and traffic information;
- "Audio": used to access the radio and playback of audio files;
- "Phone"/"Replication":
  - can be used to pair one or more phones to the system or to access

calls, the phonebook and other available functions on the phone that is connected to the multimedia system;

- can be used to enable smartphone replication.

- "Applications": can be used to access the apps;
- "Vehicle": used to manage some vehicle equipment, such as the Drive Mode, the driving assistance systems, the 360° camera, the My driving and to adjust various settings on the multimedia system, e.g. display, language etc.)

## Introduction to the Menu pages

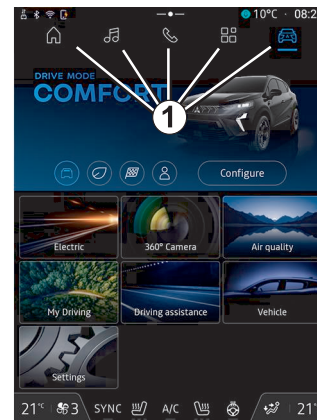

Move from one Menu to another by pressing directly on one of the Menu buttons **1**.

## OPERATING PRINCIPLES

The "Home page" or "Navigation" Menu include widgets providing access to functions such as tyre pressure adjustment, the radio, etc.

These widgets grant you direct access to the main screen for the function or, in certain cases, enable you to directly control them from one of the main screens (change the radio station, for example).

**Note:** you can change the configuration of the "Home page" or the "Navigation" page. Please refer to the "Add and manage widgets" section for further information → 20.

### Notification centre

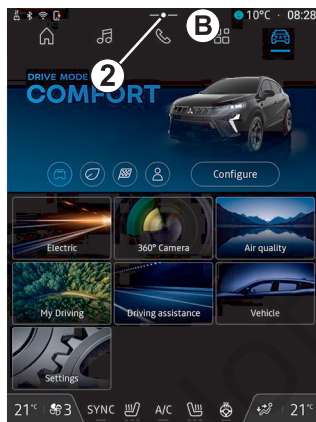

Can be accessed using button **2** or by quickly swiping the multimedia screen from area **B** towards the centre of the screen. The Notifications centre enables access to the notification history, for example:

- SMS ;
- « Tyre pressure » ;
- available updates;
- ...

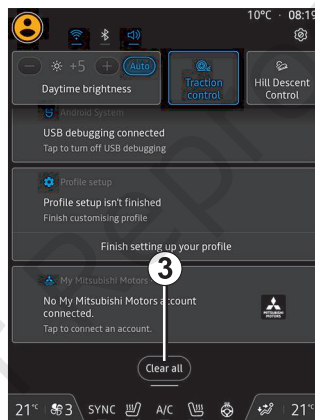

Select a notification to access it.

To delete a notification, perform a quick swipe on the screen.

To delete all notifications, press button **3**.

You can also create and configure your user profile. For further information,

please refer to the section on "User settings" → 95.

For more information on notifications, please refer to the "Notifications" section → 102.

### Functions unavailable

While driving, functions such as access to the tutorial and some settings may be unavailable, according to country-specific regulation.

To access unavailable functions, stop your vehicle.

**Note:** in some countries, regulation requires that the parking brake be applied in order to access the applications. For further information, please contact an approved dealer.

## CLEANING

### Cleaning recommendations



Do not pour or spray the cleaning product on the screen.

Do not use chemical cleaning agents or household products. The device should not come into contact with any liquids and should not be exposed to dampness. If so, surfaces or electrical components may be degraded or damaged.



Do not use products containing alcohol and/or spray fluids on the area.

**Use only a clean, lint-free, soft dry micro-fibre cloth** to clean the touchscreen so as not to damage the anti-glare materials.

Do not apply too much pressure on the multimedia screen and do not use cleaning equipment that may scratch the screen (e.g. brush, rough cloth, etc.).

### "Cleaning screen" mode

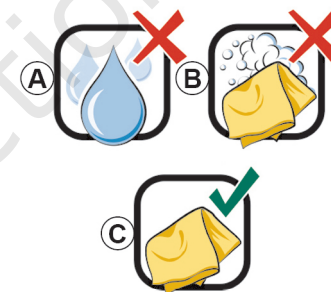

To use a micro-fibre cloth on the multimedia system screen when it is on, briefly press the control **1** on the multimedia panel, then press "Cleaning screen" **2** to set the touchscreen to inactive mode.

To exit the mode "Cleaning screen", press the multimedia screen twice.

Observe the following cleaning recommendations:

**A.** : do not use alcohol-based fluids, do not apply or spray fluids;

**B.** : do not clean with soapy water using a slightly moistened micro-fibre cloth;

**C.** : dry clean using a micro-fibre cloth.

## SWITCHING ON, OFF

### Switching on



The multimedia system starts:

- when the doors are opened;
- by briefly pressing the multimedia panel control **1**.

### Switching off



The multimedia system can be switched off:

- by briefly pressing the control **1** on the multimedia panel, then by pressing on "Stand-by";
- when the opening elements of your vehicle are locked.

### Minimum display

This function allows you to display only the exterior temperature, the clock and the heating level bar on the screen.

To select this display mode, briefly press the control **1** on the multimedia panel, then press the "Minimal display" function.

Other functions will be displayed when you briefly press the control **1**:

- « Radio - Music OFF »/« Radio - Music ON » ;
- « Cleaning screen ».

### Restart

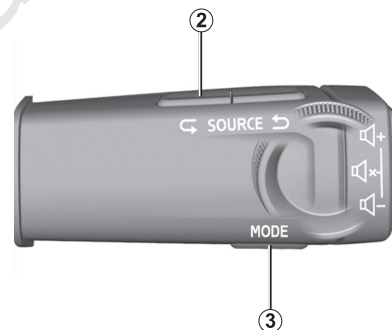

The multimedia system can be restarted by pressing and holding (press and hold until the system restarts):

- on the multimedia panel control **1**;
- or
- on the "Mode" button **3** and the left-hand "Source" button **2** on the steering column control.

## ADD, MANAGE WIDGETS

### Introduction



For safety reasons, carry out any adjustments while the vehicle is stationary.



Widget configuration is linked to the profile. If the profile changes, the widgets display changes too.

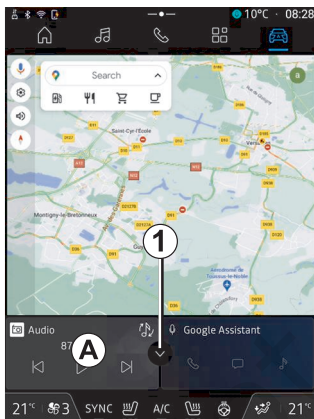

Your system has a customisable "Home page" or "Navigation". This is made up

of a number of widgets in area **A** that enable access to information and functions such as the My driving, radio, tyre pressure adjustment, etc.

Press one of the widget controls to directly control the function via the main screen (change the radio station, access the phone, etc.).

### Widget size

To allow more visibility to the navigation map, you can reduce the widget area.

Press button **1** or swipe the multimedia screen from the widgets area **A** towards the edge of the screen.

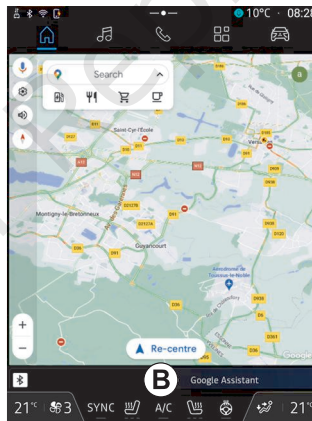

To enlarge the widgets screen, press the widget or quickly swipe the multimedia

screen from the widgets area **B** towards the centre of the screen.

### Customising the widgets

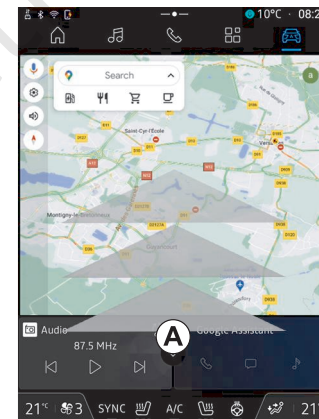

From the "Vehicle" Menu , the "Vehicle" menu, "Cockpit", then "Edit widgets" you can customise the widgets.

You can also customise the widgets:

– from the "Home page" Menu  by pressing and holding the widget that you wish to customise;

or

– from the "Navigation" Menu  by "swiping" from zone **A** towards the

## ADD, MANAGE WIDGETS

centre of the screen, then by pressing and holding the widget that you wish to customise.

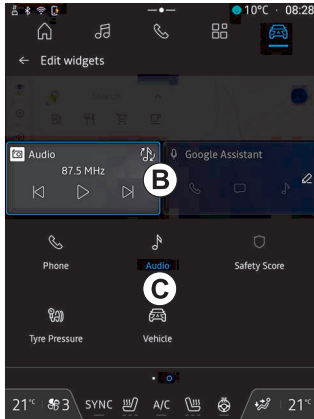

Then select the desired location in area **B** simply by touching the screen and select the widget that you wish to display from the list **C**.

## USING VOICE RECOGNITION

### Introduction

Depending on the equipment, your multimedia system is equipped with a voice recognition system:

- « Google Assistant » ;
- voice command via smartphone replication.

The voice recognition system can be used to control some functions on the multimedia system and on your smartphone by voice command. You can use your multimedia system or your smartphone while keeping your hands on the steering wheel.

Use the voice command by addressing the multimedia system as if you were speaking to a person naturally.

**Note:** the position of the voice recognition button may vary. Please refer to the vehicle user manual for further information.

You can use the voice recognition systems:

- of the multimedia;
- of the smartphone available via smartphone replication.

For more information on smartphone replication, please see the "Android Auto™ , CarPlay™" ➔ 67.

### Using the multimedia system's voice recognition

#### Main functions controlled by the voice command of your multimedia system

Some voice commands can be used to access the following vehicle functions:

- Navigation;
- Music;
- Radio;
- Phone;
- Vehicle functions (air conditioning, Drive Mode);
- Connected services (weather, news, etc.);
- ...

**Note:** if you wish to use voice recognition, make sure that you are located in a network coverage area. Certain functions cannot be accessed in the event of poor reception.

Connecting to an account Google® enables you to further customise the assistant when the vehicle is connected. For example, it is possible to call saved contacts or to find out about the content of the calendar Google®.

#### Note:

- "Google Assistant" is not yet available in all languages. For more information on availability or to try another language (on condition of availability), please see [support.google.com](https://support.google.com);

- voice commands become enriched and improve with software updates;
- the instructions below are general descriptions and include third-party vendors. The availability, version and functionality may vary or be modified.

### Voice controls

(depending on equipment)



You can use voice control to call a contact in your phonebook, enter a destination and change the radio station without touching the screen. Briefly press button **1** and an audible confirmation will sound along with a visual confirmation on the screen.

## USING VOICE RECOGNITION

**Note:** this function is only available on vehicles equipped with the navigation system.

### "Google Assistant" activation

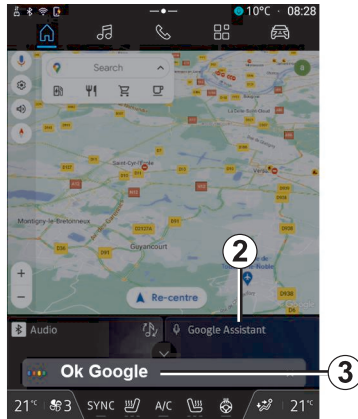

There are several ways to activate the voice recognition system:

– after stating the "Ok Google" or "Hey Google" voice command and receiving audible feedback and visual feedback on the screen **3**, state your request (e.g. "Go home");

or

– by briefly pressing the voice recognition button **1** in your vehicle;

or

– by pressing the widget "Google Assistant" **2**;

or

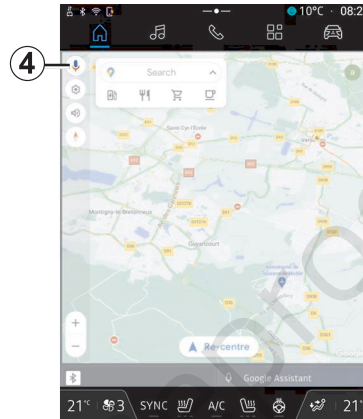

– by pressing the **4** icon from the

"Navigation" .

### "Voice recognition" menu

From the "Vehicle" Menu , "Settings", "Google®", then "Google Assistant", you can:

- select the assistant's "Language";
- activate/deactivate the "Say Ok Google" voice command;
- authorise custom results;
- proactively display custom results;

– receive notifications from the "Google Assistant".

### "Navigation" control with voice recognition

There are several methods available to enter a destination using the voice control included with your multimedia system.

**Note:** to benefit from all of the features, you must activate your Google® account and have saved addresses. For further information, please refer to the section on "User settings" → **99**.

To start a voice command linked to navigation, activate the voice command then, after the beep, state your command in relation to one of the following topics:

- "Points of interest";
- "Destination";
- "Home";
- "Work";
- "Route information";
- "Guidance";
- ...

#### "Points of interest"

To search for a POI (point of interest) using the voice command.

Examples:

- "Go to the baker";
- "Drive me to the Paris train station";

## USING VOICE RECOGNITION

- "Take me to the Eiffel Tower";
- ...

### "Destination"

To enter a complete address using voice command.

Examples:

- "Go to 7 rue de la Joie, Paris";
- "Take me to Paris";
- "Go to Montmartre, Paris";
- ...

**Note:** the examples can be adapted according to the country and the language.

### "Home" and "Work"

To get to your home or work using voice command.

Examples:

- "Go home";
- "Drive me home";
- "Take me to work";
- ...

**Note:** to use the "Go home" or "Go to work" voice function, you must enter a Google® account and save an address.

### "Route information"

To be informed of the route in progress using voice command.

Examples:

- "What is my route?";
- "What is the arrival time?";
- "What is the remaining distance?";

- ...

### "Guidance"

To take action on current route guidance using voice command.

Examples:

- "Activate/deactivate the voice guidance";
- "Avoid toll roads";
- "Cancel the route";
- ...

### "Audio" command with voice recognition

You can activate the music or radio using the voice command included in your multimedia system.

To launch a voice command related to

the "Audio" , activate the voice command then, after the beep, state your command in relation to one of the following topics:

- "Audio source";
- « Radio » ;
- "Music";
- "Playback commands";
- ...

#### "Audio source"

You can change the audio source.

Example:

- "Play the radio";

- "Launch the streaming music app";
- ...

### « Radio »

You can choose the radio station.

Example:

- "Play Jazz radio";
- "Play 91.8";
- ...

### "Music"

You can launch music (an audio track, playlists, etc.) only for streaming music.

Example:

- "Listen to <name of artist>, with <name of preferred application>";
- "Listen to <song title>, with <name of preferred application>";
- "Listen to <name of album>, with <name of preferred application>";
- "Play <name of playlist>, with <name of preferred application>";
- ...

**Note:** some streaming music applications require an associated account to be connected to it.

### "Playback commands"

You can command the current playlist.

Example:

- "Playback";
- "Pause";
- "Next";
- "Previous".

## USING VOICE RECOGNITION

**Note:** the commands may vary or may not be available depending on the application used.

### "Phone" command with voice recognition

It is possible to call a number or a contact using the voice control included with your multimedia system.

To launch a voice command related to

the "Phone" , activate the voice command then, after the beep, state your command in relation to one of the following topics:

- "Call";
- "Dial";
- "Call log";
- « SMS » ;
- ...

**Note:**

- you must activate data sharing on your phone, for more information please refer to the section on "Activating services" ➔ 11;
- you must activate authorisation of the customised results in the Google® settings. For more information please refer to the "System settings" section ➔ 99.

### "Call" and "Dial"

You can call a contact available in your phonebook or dial a telephone number.

Examples:

- "Call Grégory";
- "Call Grégory home";
- "Call my voicemail";
- "Dial 06 77 07...";
- "Dial 06 77 07...";
- ...

### "Call log"

You can view the call history for your phone.

Example:

- "Call log";
- "Display calls";
- "Recent calls";
- ...

### « SMS »

You can dictate and send an SMS or have an SMS read out.

Example:

- "Send to Fabien 'Let's meet later for ...'";
- "Read the SMS";
- "Reply to the SMS";
- ...

**Note:**

- you must activate data sharing so that you can have the SMS read by your multimedia system, for more in-

formation please refer to the section on "Activating services" ➔ 11;

- you must activate authorisation of the customised results in the Google® settings. For more information please refer to the "System settings" section ➔ 99;
- only SMS received while driving can be read by the multimedia system.

### "Vehicle functions" command with voice recognition

You can activate some of your vehicle's functions using the voice command integrated into your multimedia system.

To launch a voice command linked to the "Vehicle" world, activate the voice command then, after you hear the audible confirmation, state your command in relation to one of the following topics:

- "Range";
- "Heating level";
- « Drive Mode » ;
- ...

### "Range"

(depending on equipment)

You can obtain certain information relating to the battery life of your vehicle.

Example:

- "Can I go to Dunkerque";

## USING VOICE RECOGNITION

- "What is my battery range?";
- ...

### "Heating level"

You can activate certain functions associated with the heating level.

Example:

- "Activate ventilation on the feet";
- "Activate the heated steering wheel";
- "Increase the passenger seat heating";
- "Synchronise the temperature";
- "Reduce the temperature";
- "Set the temperature to 21 degrees";
- ...

### « Drive Mode »

You can activate the various Drive Mode modes.

Example:

- "Activate ECO mode";
- "Change to Sport mode";
- "Activate Comfort" mode;
- ...

### "Connected Service" command with voice recognition

You can ask the connected services certain questions using the voice command included in your multimedia system.

To launch a voice command linked to the "Connected services", activate the voice command then, after the beep,

state your command in relation to one of the following topics:

- "Weather";
- "News";
- "Sports";
- "Events";
- ...

Example:

- "What is the weather like in Paris ? train station";
- "What is today's news?" train station";
- "What is the match score"? Paris – Marseille ? train station";
- ...

### Using voice recognition by smartphone replication

#### Main functions controlled by your smartphone's voice command

When the smartphone is connected to the multimedia system via smartphone replication, some voice commands can be used to access the domains and apps available on the smartphone.

For more information on smartphone replication, please see the "Android Auto™, CarPlay™" section → 67.

Some voice commands can be used to access the following smartphone functions:

- Navigation ;
- Music;

- Phone ;
- ...

**Note:** if you wish to use your smartphone's voice recognition with the multimedia system, make sure that you are located in area with network coverage.

### Smartphone replication command with voice recognition



When you use voice recognition using smartphone replication, you use your phone's Internet connection, which is subject to charges and limitations imposed by your mobile operator.

To use your smartphone's voice recognition system with your multimedia system, you must:

- ensure that your smartphone has a voice recognition function that is compatible with your multimedia system;
- connect your smartphone to the multimedia system via smartphone replication.

For more information, please refer to "Connecting, disconnecting a phone" → 54 and "Android Auto™, CarPlay™" → 67.

## USING VOICE RECOGNITION

### Voice controls

(depending on equipment)



You can use the smartphone replication voice command without using the screen by long-pressing button **1**; a confirmation will then sound and be displayed on screen.

### Activation

To activate the voice recognition system:

- press and hold the voice recognition button **1** in your vehicle;

– from the "Replication" Menu 



, press the voice command associated to the application in use.

**Note:** when using voice recognition, always wait for an audible confirmation to sound before speaking.

To start a voice command linked to applications compatible with voice recognition, activate voice command, then say your request after the sound signal.

Using the phone application via smartphone replication, using voice command.

Example:

- "Call José";
- "Call the office";
- ...

Using the navigation application for smartphone replication, using voice command.

Example:

- "Go to Champs-Élysées in Paris";
- "Go home";
- ...

**Note:** the commands used for voice recognition depend on the application on the replicated smartphone.

# MAP

## Map

2



For safety reasons, carry out any adjustments while the vehicle is stationary.

### Displaying the map

Press the "Navigation" Menu  1 to access the map.

You can also access the map from the

"Applications" Menu , then "Maps".

The map tells you your current position and various information that you configured (display POI, points of interest, traffic information etc.).

To move around the navigation map, drag the desired direction on the screen.

Press "Recentre" to return to your current position.

#### Note:

– "Maps" is the default navigation app. Other apps may be available to download from "Play Store™", which can be

accessed from the "Applications"

Menu ;

– the map is updated automatically without any need for action on your part.

### "Map" screen without a route in progress



1. "Navigation" Menu .

2. Guidance voice settings: "Deactivated", "Alerts only" or "Reactivated".

3. View mode to display as "North at the top" (2D/North), "User view" (2,5D) or "Overview".

4. Zoom on the map: press the "+" / "-" button to zoom in/zoom out on the map.

**Note:** you can also zoom in or out by widening or narrowing the gap between your two fingers on the screen.

5. Name of the street which you are on. Press to access additional features.

## MAP

6. Navigation settings.
7. Your current position.
8. Card.
9. Destination search bar.
10. Re-centre map after exploring it.

### "Map" screen with a route in progress



2. Guidance voice settings: "Deactivated", "Alerts only" or "Reactivated".
3. View mode to display as "North at the top" (2D/North), "User view" (2,5D) or "Overview".
4. Zoom on the map: press the "+" / "-" button to zoom in/zoom out on the map.
6. Navigation settings.
7. Your current position.
8. Map with route display.
10. Re-centre map after exploring it.
11. Lane and direction you should follow to continue on your calculated route.



12. Journey information such as the arrival time, traffic info and the remaining distance to the next stage or final destination (depending on the configuration) etc.
13. "Choose another route".
14. "Search along the route".
15. "Route overview".
16. "Stop navigation".

### Navigation by replication display on the instrument panel



(depending on equipment)  
The replication navigation via "Android Auto™" can be displayed on the instrument panel screen. 17.

## MAP

For more information on the instrument panel display, please refer to the vehicle user manual.

2

### Guidance voice settings



To set the guidance voice, press **2** to select one of the following options:

- "Deactivated" **18**;
- "Alerts only" **19**;
- "Reactivated" **20**.

**Note:** if you select the "Deactivated" function, no voice guidance instructions will be emitted by the multimedia system.

### Display mode



You can change the map view by pressing the **3** button.

#### "North at the top view" (2D/North) **21**

The map displays your current position facing North.

### "User view" (2,5D) **22**



The map displays your current position on a 3D map surface.

It automatically faces the direction of travel.

To change the tilt of the relief map, slide your two fingers on the screen from bottom to top or from top to bottom.

# MAP

## "Overview" 23



The map displays your current north-facing position as well as the overview of the route in progress.

**Note:** this view is only available when a route is in progress.

### Guidance

Guidance is activated once the route has been calculated. The multimedia system guides you all the way along your route, informing you at each intersection of the direction to follow over several stages.

#### Stage 1: preparation

The multimedia system will inform you, using the navigation voice, that you will soon have to carry out a manoeuvre.

#### Stage 2: alert

The multimedia system announces the manoeuvre that you need to carry out. e.g. "In 400 metres, take the next exit".

#### Stage 3: manoeuvre

The multimedia system indicates which manoeuvre should be carried out.

e.g. "Take the next right".

**Note:** if you do not follow the driving recommendations or if you quit the calculated route, a new route is automatically recalculated by the multimedia system.

## "Route overview"



This function is used to view the details of the current route.

From the "Route overview" icon 15, you can view:

- the current route in detail;
- the starting point and destination, as well as the various suggested routes;
- the various stages, distances and durations for each stage;
- ...

## ENTER A DESTINATION

### Enter a destination

2



#### Precautions regarding navigation

Use of the navigation system does not in any way replace the responsibility or vigilance of the driver when driving the vehicle.



For safety reasons, carry out any adjustments while the vehicle is stationary.



Certain functions are only available while the vehicle is stationary.

From the "Navigation" Menu  **1**, press the destination search bar **2**.

### Using voice recognition to enter an address

Activate voice command, then state the name of a town, a number and/or street name, a destination area.

For more information, see the section on "Using voice recognition" → 22.

**Note:** to benefit from all the navigation functions, please connect to your Google® account.

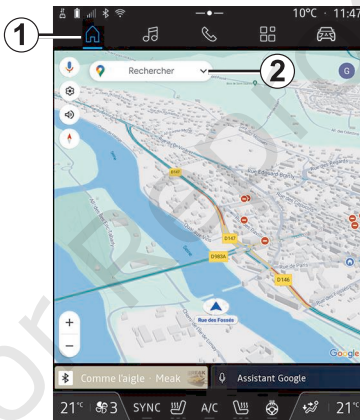

From the destination search bar **2** you can access:

- recent destinations;
- categories (POI: points of interest);
- saved addresses (home, work, favourites, etc.).

**Note:** the activation of location and data sharing is required in order to use the online destination search function. Please see the section on "Activating services" → 11.

### "Home" and "Work" destinations

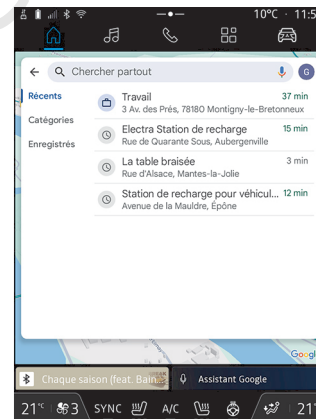

From the search bar, you can run navigation guidance to your "Home" or "Work" location.

When you select "Home" or "Work" for the first time, the system asks you to register an address.

**Note:** only one "Home" and one "Work" address can be stored by the multimedia system.

## ENTER A DESTINATION

### Finding an address

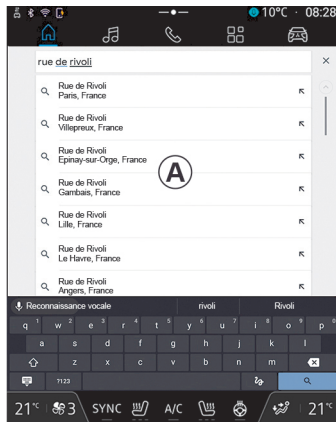

From the search bar **2**, you can enter a full or partial address (country, town, postcode, street, street number, intersection, etc.).

When you start entering letters, the system suggests similar street names. You can:

- press the street name displayed on the screen to confirm your selection;
- browse the list **A** of suggested streets to see the full list corresponding to your search.

### Search for a destination

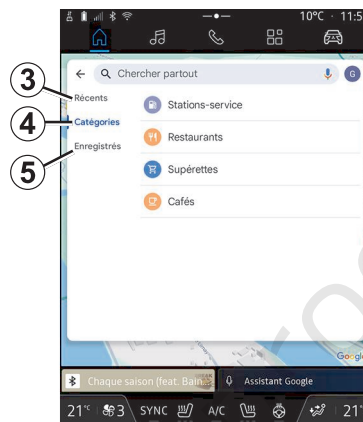

From the destination search bar **2**, you can access the tabs for the following different types of destinations:

- "Recent" **3**;
- "Categories" **4**;
- "Save" **5**.

### Recent destinations **3**

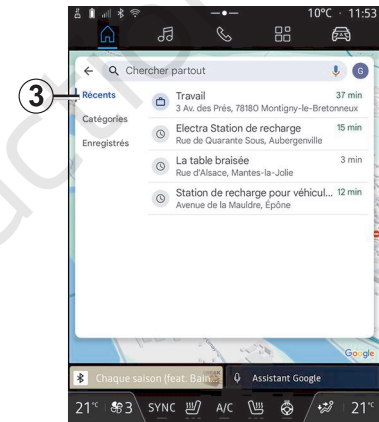

From the search bar, select the "Recent" tab to access the list of recently-used destinations. These are automatically stored from the multimedia system and from the devices connected to your "Google®" account.

Select a destination to start guidance.

2

## ENTER A DESTINATION

### Destinations by category 4

2

4

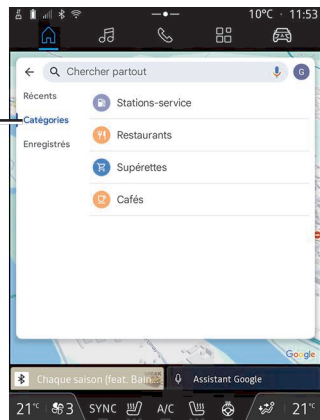

From the search bar, select the "Categories" tab to access a list of POI categories (point of interest):

- "Service stations"/"Recharging terminals";
- "Restaurants";
- "Convenience stores";
- "Cafes".

A POI (point of interest) is a service, establishment or tourist attraction close to a location (start point, destination city, on the route etc.).

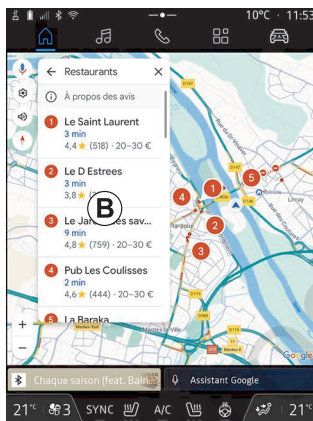

After you have selected a category, the multimedia system will offer a list of POI at **B** and on the map. You can:

- press the POI displayed at **B** to confirm your choice;
- browse the list **B** of POI on display to access the full list corresponding to your search.

**Note:** the list of POI is updated in real time by "Google Maps™".

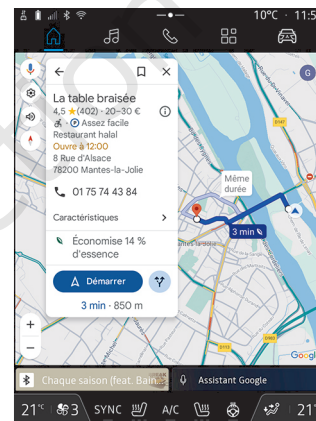

After you have selected a POI, the multimedia system displays the following information (if available):

- address, opening times, opinions, etc.;
- phone number;
- time of arrival, distance;
- route overview;
- ...

## ENTER A DESTINATION

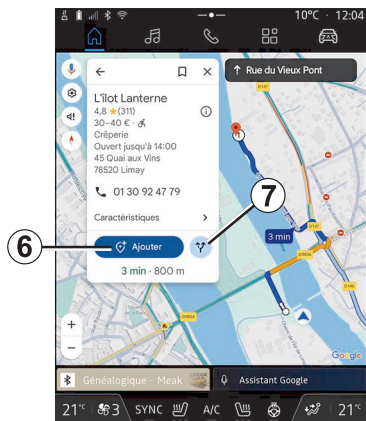

You can also search for a POI with a route already in progress.

**Note:** the search for POI is based on your position when the request is made. If the search is for another geographical area, enter the desired location.

After searching and selecting a POI, the multimedia system displays the information (if available) and its location along the route in progress.

To display the route in progress, press **7**.

To add a stop at POI on the route in progress, press **6**.

### "Save" 5

You can access the places you have saved:

- "With text";
- "Favourites";
- "Saved";
- "To visit";
- "Contacts".

**Note:** the saved locations are synchronised with your account Google® even if they are used on other devices connected to your account.

### "Browse the map"



To explore the map, move the map by keeping your finger pressed on the screen while dragging it.

To zoom in/out on the map, press the buttons **9** or widen/narrow the gap between your two fingers on the screen.

To recentre the map, press the "Recentre" button **8**.

### Entering a destination when a route is in progress

When a route is in progress, you can access the following functions:

- "Choose another route" **12**;
- "Search along the route" **10**;
- "Navigation settings" **13**;
- "Stop navigation" **14**;
- "Route overview" **11**;
- ...

## ENTER A DESTINATION

### "Choose another route" 12

2



To view the other routes suggested by the multimedia system, press **12**.

### "Search along the route" 10

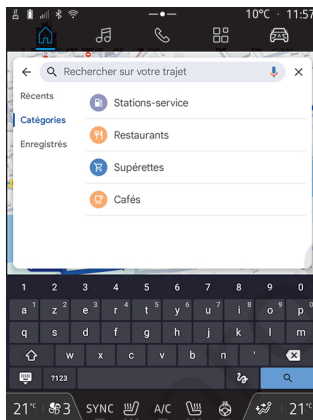

This function enables you to search for and/or to add one or more stages to your route in progress. You can add:

- a search using voice recognition;
- "Service stations";
- "Restaurants";
- "Convenience stores";
- "Cafes".

### "Settings" 13

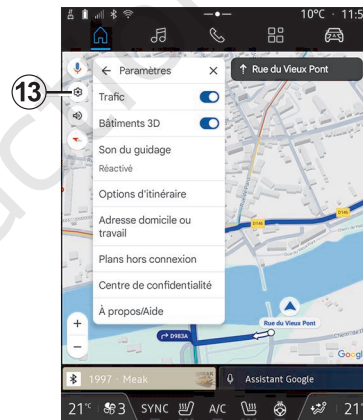

Use this menu to access the following navigation settings:

- "Traffic";
- "3D buildings";
- "Guidance sound";
- "Route options";
- "Change the address of the home or work place" (if saved already);
- "Offline maps";
- "Confidentiality centre";
- "About/Help".

For further information on the "Settings", see the section on "Navigation settings" → **38**.

## ENTER A DESTINATION

### "Stop navigation" 14

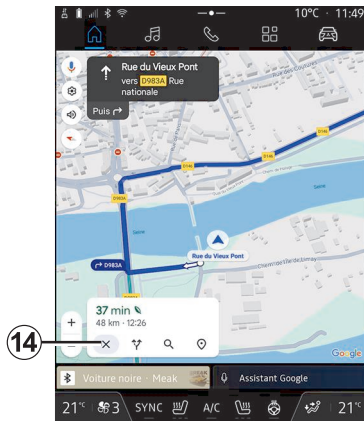

Use this function to cancel the current route. Press **14** to stop the current navigation.

### "Route overview" 11



From the route overview **11**, you can view the route in progress as well as other alternative routes.

By pressing on one of the routes, you can view the journey and its distance and duration.

# NAVIGATION SETTINGS

## "Settings" Menu

2



For safety reasons, carry out any adjustments while the vehicle is stationary.



From the "Navigation" Menu  , press the "Settings" icon **1** to access the navigation settings.

From the "Settings" icon **1** you can access the following settings:

- "Traffic" **2**;
- "Guidance sound" **3**;
- "Route options" **4**;
- "Offline maps" **5**;
- "Confidentiality centre" **6**;
- "About/Help" **7** ;
- activate/deactivate the "Traffic" function **8**;
- "3D buildings" **9**;
- activate/deactivate the "3D buildings" function **10**;
- "Home or work address" **11**.

## "Traffic" 2

This function enables you to receive real time traffic information such as:

- traffic information and incidents in your area;
- accidents, road works or closure of nearby roads;
- ...

Press **8** to activate/deactivate the "Traffic" function.

## "Guidance sound" 3



From this setting, you can:

- mute the sound of the "Navigation" **12**;

## NAVIGATION SETTINGS

- mute the sound of the "Navigation" and keep only the sound of the "Traffic" alerts **13**;
- reactivate the voice guidance sound **14**;
- test the sound of the "Navigation" to adjust the volume of the voice guidance **15**.

### "Route options" 4

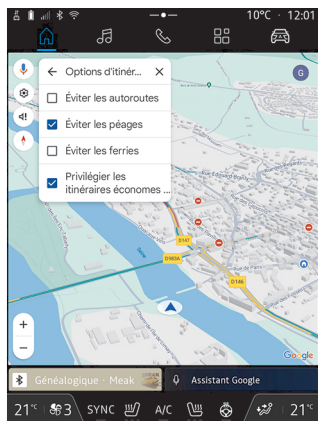

From this setting, you can activate/deactivate the following route options:

- "Avoid major roads";
- "Avoid toll roads";
- "Avoid ferries";
- "Give priority to energy efficiency".

### "Offline maps" 5

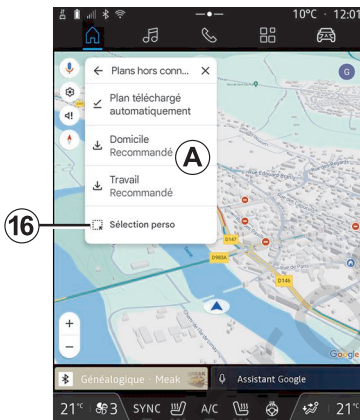

Offline maps enable you to download and save maps in your multimedia system so they can be used when you go to a location where the Internet connection is slow, cannot be accessed or do not wish to use an Internet connection.

The list of offline maps is available at **A**.

To add an offline map to "Custom selection", press **16**.

### Custom selection



This function can be used to select an area on the map and its information to be downloaded.

Pan and zoom the map to adjust the selection to be downloaded.

## NAVIGATION SETTINGS

### "Confidentiality centre" 6

2

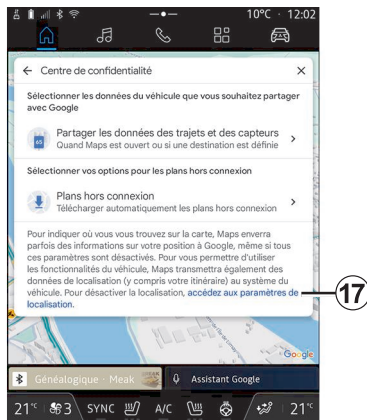

From this menu, you can configure the following data to be shared:

- "Share driving data with Google®";
- "Offline maps".

To directly access the vehicle's location settings, press "Access the location settings" 17.

### "Share driving data with Google®"

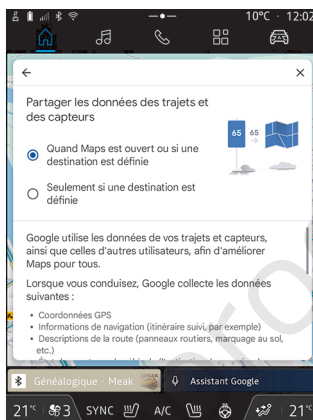

Your driving and location data can be shared with Google®. These can be used to improve the information provided to you and other users by Google®, such as navigation, traffic conditions in real-time, availability of "Offline maps", etc.

Sharing may be:

- "Deactivated";
- activated only "During detailed navigation";
- "Always activated".

### Options for "Offline maps"

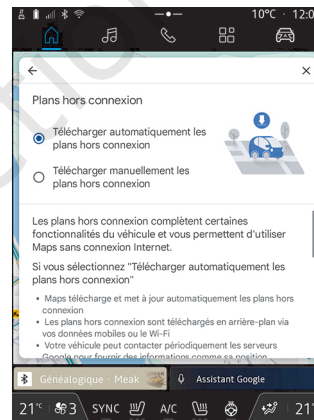

You can choose to download the offline maps update as follows:

- automatically;
- or
- manually.

**Note:** for more information, refer to the details and instructions displayed on the multimedia screen.

## NAVIGATION SETTINGS

### "About/Help" 7

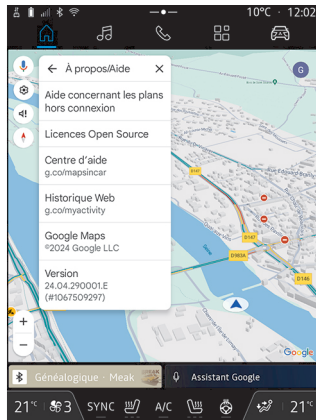

From this menu, you can access the information and using the following elements:

- "Help with offline maps";
- "Open Source licence";
- "Help centre";
- "Web history";
- « Google Maps™ » ;
- "Version";
- ...

### "3D buildings" 9

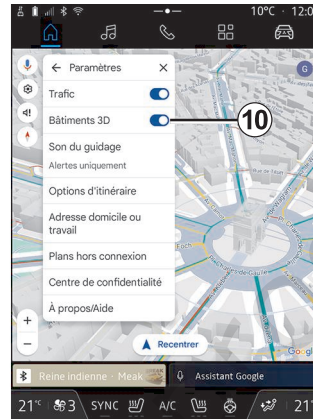

You can choose to display buildings in 3D where the mapping allows it. Press **10** to activate/deactivate the function.

### "Home or work address" 11

You can set up your home and work address from this menu.

# AUDIO SOURCES

## Introduction

3

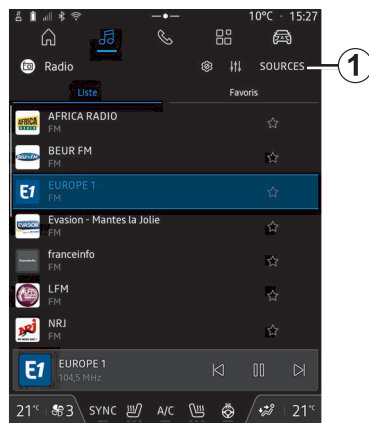

From the "Audio" Menu , you can select the audio source by pressing "Sources" **1**.

You can also select the audio source using the steering column control. For more information please see the "Introduction to the controls" section **➔ 9**.

Audio sources may vary according to the equipment level.

Only the audio sources available and downloaded from the "Play Store™" app appear and can be selected on the multimedia screen.

## "Audio sources" screen



2. "Android Auto™" source.
3. "CarPlay™" source.
4. "Bluetooth® audio" source.
5. "App" source.
6. Exit the "Audio sources" screen.
7. "USB" source (USB port).
8. "Radio" source.
9. "Podcasts" source.
10. "Google News" source.

### « Android Auto™ »

Use this source to listen to music from your smartphone, if equipped with the "Android Auto™" app, via smartphone

replication. For more information, please refer to the "Android Auto™, CarPlay™" **➔ 67** and "Music" **➔ 48** sections.

### « CarPlay™ »

Use this source to listen to music from your smartphone, if equipped with the "CarPlay™" service, via smartphone replication. For more information, refer to the "Android Auto™, CarPlay™" section **➔ 67**.

### "Bluetooth® audio"

This source can be used to listen to the music on your smartphone via the Bluetooth® connection. For further information, please refer to the "Music" **➔ 48** and Connecting/disconnecting a phone" section **➔ 54**.

### "App"

Use this source to listen to music via streaming music apps and to access your audio apps downloaded via the "Play Store™" app. For further information, please refer to the "Music" **➔ 48** and "App management" **➔ 71** sections.

### « Radio »

You can use this source to listen to the radio. For more information, refer to the "Radio" section **➔ 44**.

## AUDIO SOURCES

### "USB" (USB port)

Use this source to listen to music from a USB drive. For further information, please refer to the "Music" section

➔ 48.

#### **Note:**

- some formats may not be recognised by the system;
- the USB drive must be FAT32 or NTFS formatted and have a minimum capacity of 8 GB and a maximum capacity of 64 GB.

### « Podcasts »

Use this source to listen to "Podcasts".

### « Google News »

Use this source to listen to "Google News".

# LISTEN TO THE RADIO

## Introduction

3



For safety reasons, carry out these operations when the vehicle is stationary.



You can select a saved station, scroll through the radio stations per list depending on the mode selected using the button on the steering column control. For more information on the steering column controls, refer to the "Introduction to the controls" section → 9.

From the "Audio" Menu , press button **3** to select the "Radio" source. You can also access the "Radio" source from the "Applications" Menu



Using the steering column control, you can select the audio source, browse through stations and change the selection mode ("List", "Favourites"). For

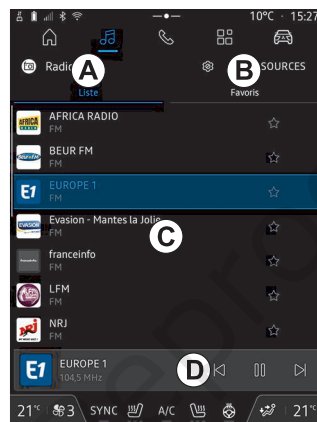

more information, refer to the "Introduction to controls" section. → 9.

## "Radio" screen

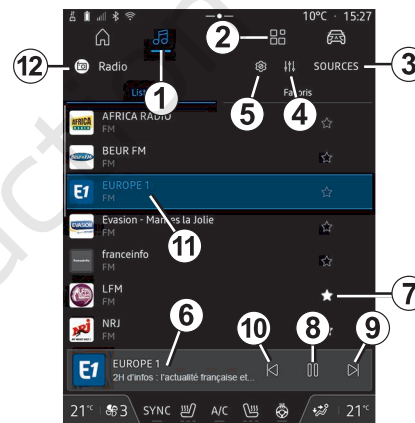

- A.** "List" mode tab.
- B.** "Favourites" mode tab.
- C.** List of stations available.
- D.** Playback area for the radio station currently playing and access to the full screen display. Press this area to display the currently playing track in full screen.



- 1.** Access the "Audio" Menu .
- 2.** Access the "Applications"  menu.
- 3.** Access the audio "Sources".
- 4.** Access the "Audio settings".
- 5.** Access the "Radio settings".
- 6.** Radio station currently playing.
- 7.** Save a station in the "Favourites".
- 8.** Stop the radio/playback of the current station.
- 9.** Go to the next station.
- 10.** Go to the last station.

## LISTEN TO THE RADIO

**11.** The name of the current station and the frequency. Text Information (radio logo, singer, song, etc.).

**12.** Type of "Sources" being listened to.

**Note:** some information is only available on certain radio stations.

### Full screen display *E*

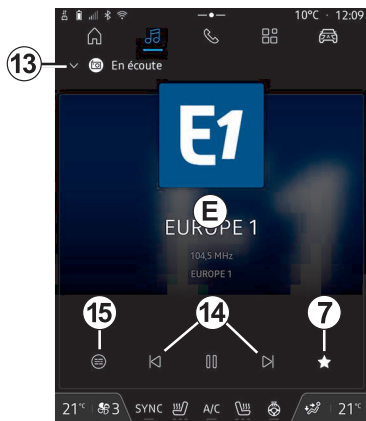

Press this area to display the radio station currently playing in area *D* when in full screen play mode.

To minimise the full screen display *E*, press **13**.

With the vehicle stationary, you can activate the "Auto-scrolling image display" by pressing the logo of the radio

station currently being played, if the current station DAB allows it.

### Select a radio band

Press the button **5** to set the following wavebands.

- « FM » :
- « Alternative Frequency (AF) » ;
- « Region ».
- "DAB" (terrestrial digital radio):
- « Switching (DAB ↔ FM) » ;
- "Auto-scrolling images".

### Radio programme

Depending on the station being listened to, you will be able to see a detailed view of the programmes currently playing and of those playing over the next 24 hours.

Press the button **15** to display the list of these programmes.

**Note:** this function is only available if the station is available in DAB version, depending on the station.

### Station search

You can search for radio stations in the current radio band in alphabetical order on the list: move forward or backward to the next station by pressing the buttons **14**.

### Add/remove a radio station to/from the "Favourites"

From the full screen display or from "List" mode, press the button **7** to add/remove the current station to/from the "Favourites".

### "List" mode *A*

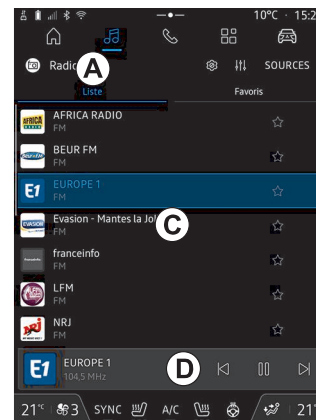

This mode enables you to search and view the stations captured by the multimedia system and listed alphabetically.

Quickly swipe the list *C* to list all of the stations.

Select a radio station from the list to listen to it directly.

The radio station currently playing is displayed in the mini player *D*. Press

## LISTEN TO THE RADIO

this area to display the current radio in full screen.

If "FM" band radio stations do not use the RDS system or if the vehicle is in an area with poor radio reception, the station name will not appear on the screen, only the frequency.

**Note:** some information is only available on certain radio stations.

### "Favourites" mode *B*

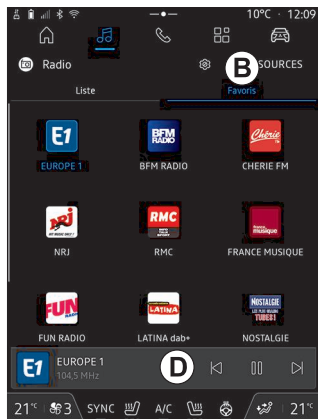

This mode allows you to access the previously stored radio stations.

Select a radio station from the list to listen to it directly.

The radio station currently playing is displayed in the mini player *D*.

### "Radio settings" menu *5*

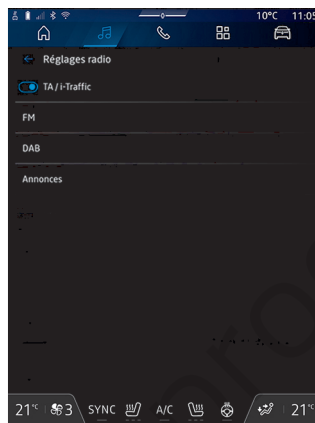

From the "Radio settings" menu *5*, you can access the following radio function settings:

- "TA/I-Traffic (depending on equipment)";
- « FM » ;
- "DAB" (depending on equipment);
- "i-Announcement" (depending on equipment and country).

### "TA/I-Traffic" (traffic information)

(depending on equipment)

When this function is activated, your audio system enables traffic bulletins to be received (depending on the

country) if they are broadcast on certain FM and DAB radio stations.

You must then select the frequency of the station that is transmitting traffic information. If you are listening to another source (USB, Bluetooth®), it will be automatically interrupted whenever traffic information is received.

### « FM »

From the settings, you can activate or deactivate the following elements:

- « Alternative Frequency (AF) » ;
- « Region ».

### « Alternative Frequency (AF) »

The frequency of an "FM" radio station may change depending on the geographical area.

Activate the "Alternative Frequency (AF)" function to continue listening to the same radio station whilst changing geographical area.

The audio system will automatically track frequency changes without interruption.

**Note:** not all radio stations offer this possibility.

Poor reception can sometimes cause erratic and annoying changes in frequency. In this case you should deactivate the automatic frequency retuning.

## LISTEN TO THE RADIO

### « Region »

When "Region" mode is activated, if the signal level drops, the radio will switch to a new frequency operating as a relay for the station you were listening to previously.

#### **Note:**

- stations in the same area sometimes broadcast different programmes or use different radio station names;
- some radio stations broadcast on regional frequencies. In this case:
  - with "Region" activated: the system will not switch to the transmitter for the new region, but the system will switch normally between the transmitters of the initial region;
  - "Region" deactivated: the system will switch to the transmitter for the new region, even if the broadcasted program is different.

### « DAB »

(depending on equipment)

From the settings, you can activate or deactivate the following elements:

- « Switching (DAB ↔ FM) » ;
- "Auto-scrolling images" (depending on equipment).

#### « Switching (DAB ↔ FM) »

When this function is activated, if the reception of the DAB station currently

playing is poor, the radio system switches automatically to an equivalent FM station (if available).

The audio system will automatically return to the digital DAB station as soon as reception is available.

**Note:** this function is only available if the station has FM and DAB versions.

#### "Auto-scrolling images"

When this feature is enabled and the current station DAB allows it, an image slideshow scrolls across the screen in full screen playback mode.

**Note:** This function is only available in a stationary vehicle, by pressing the logo of the radio being played.

#### « i-Announcement »

(depending on equipment and country)

When this function is activated, it is possible to automatically listen to news as soon as it is broadcast by certain "DAB" radio stations.

If you then select the other sources, when a broadcast of the selected programme type is made, it will interrupt the other sources.

From the settings, you can activate/deactivate announcements for the following topics:

- "Emergency";
- "Incident";

- "Weather";
- "News";
- "Event";
- "Sport";
- "Miscellaneous".

#### « Audio settings » 4

From the icon **4** you can adjust the audio settings.

For further information on the available settings, see the section on "Audio settings" ➔ 51.

# MUSIC

## Introduction

3



For safety reasons, carry out any adjustments while the vehicle is stationary.



You can change the audio source using the button on the steering column control.

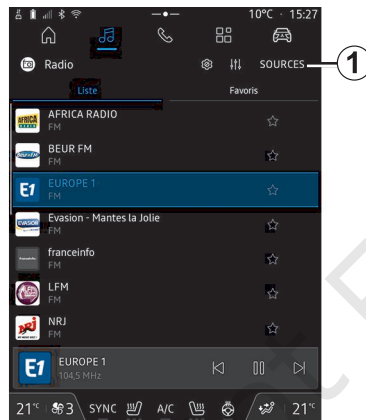

From the "Audio" Menu , press "Sources" **1** to select the music source to listen to.

Using the steering column control, you can select the audio source to listen to and browse through the music tracks and folders. For more information, refer to the "Introduction to controls" section. → **9**.

The music sources may vary according to the equipment level. Only the sources that are available are displayed and can be selected on the multimedia screen.

### Note:

- depending on the audio streaming application used, the display and controls may change;
- some formats may not be recognised by the system;
- the USB drive must be FAT32 or NTFS formatted and have a minimum capacity of 8 GB and a maximum capacity of 64 GB.

## "Sources" menu **1**

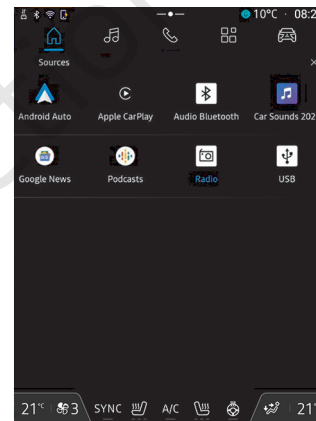

From the "Sources" menu **1** you can select music from the various sources available.

Select an input source connected to the multimedia system from the following list:

- « Radio » ;
- "USB" (USB port);
- "Bluetooth® audio";
- « Podcasts » ;
- « CarPlay™ » ;
- « Android Auto™ » ;
- audio streaming app;
- ...

The music sources may vary according to the equipment level.

## MUSIC

**Note:** other media sources can be installed via "Play Store™" and will appear in the list of available sources. For more information on installing apps, please refer to the section on "Managing apps" → 71.

### "Play" mode



**A.** Information on the audio track currently playing (song title, artist name, album title and image of the cover, if transferred from the source).

2. Access the "Audio" Menu .
3. Access the current playlist;
4. Time and length of the audio track playing.

5. Activate/deactivate the audio track repeat once or continuous repeat.

6. Play the next audio track.

7. Pause/resume the audio track.

8. Briefly press: return to the start of the current audio track.

Briefly press again (within 3 seconds after the first brief press): play the preceding audio track.

9. Activate/deactivate random playback of the audio tracks.

10. Currently playing audio track progress bar.

11. Return to list mode with mini player.

#### **Note:**

- you can choose to display the music playing in full screen **A** or in the mini player **B**;
- depending on the phone and streaming music application, certain functions may not be available.

### "Bluetooth®", "USB" and audio streaming application

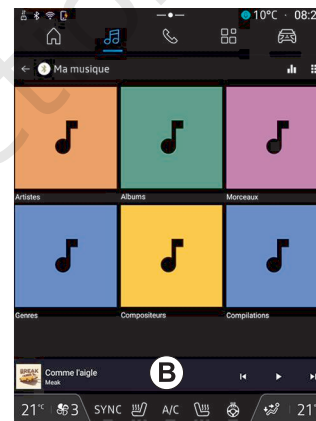

From the "Bluetooth® audio", "USB" source or the streaming music application, you can access playlists by category:

- « Artists » ;
- « Albums » ;
- « Songs » ;
- « Playlists » ;
- ...

The currently playing track is displayed in the mini player **B**. Press this area to display the currently playing track in play mode **A**.

## MUSIC

### "Search"

(Depending on the type of "Sources")



By pressing the "Search" icon **12**  
(availability depends on the type of

"Sources" in the "Audio" Menu ,  
can search for:

- a track title;
- an album;
- an artist;
- a Playlist;
- ...

Enter the name using the keyboard.

As soon as you enter the first letters,  
the multimedia system suggests asso-  
ciated names.

Select the name from the list of sug-  
gestions.

### "Audio settings" **13**

From the icon **13** you can adjust the  
audio settings.

For further information on the available  
settings, see the section on "Audio set-  
tings" → **51**.

# AUDIO SETTINGS

## Introduction



For safety reasons, carry out any adjustments while the vehicle is stationary.

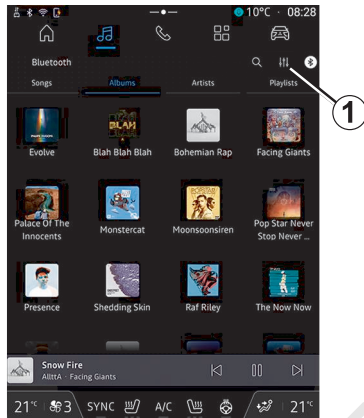

From the icon **1** you can adjust the following audio settings:

- « Ambiance » ;
- « Sound ».

### « Ambiance »

(depending on equipment)

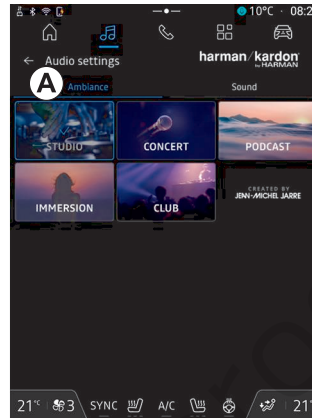

From the tab **A** you can select one of the following pre-defined musical equalisers:

- « Studio » ;
- « Concert » ;
- « Podcast » ;
- « Immersion » ;
- « Club » ;
- ...

**Note:** the availability of music equalisers depends on the equipment.

### « Sound »

(depending on equipment)

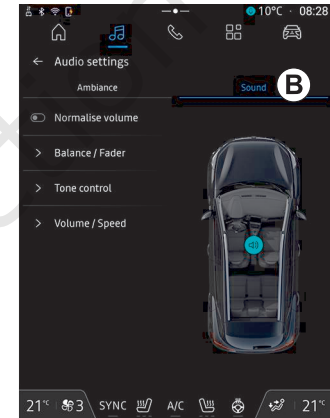

From the tab **B** you can adjust the following settings:

- « Balance / Fader » ;
- « Tone control » ;
- « Volume / Speed » ;
- « Normalise volume ».

## AUDIO SETTINGS

### « Balance / Fader »

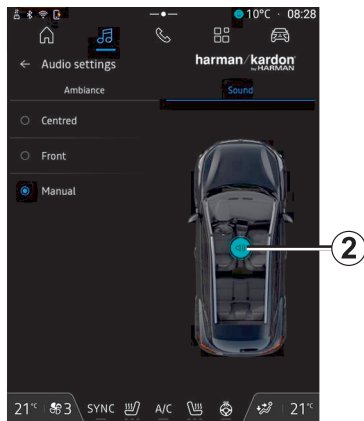

This function sets the sound distribution balance. Press "Centred" or "Front" to optimise the sound distribution for all the vehicle occupants or for the comfort of rear passengers (audio muted in the rear and moderate volume at the front of the vehicle).

When you touch the screen or when "Manual" is selected, you can then change the settings by moving the target 2.

### « Tone control »

This function can be used to equalise the audio:

- activate/deactivate "Bass boost";

- « Bass » ;
- « Medium » ;
- « Treble » ;
- ...

### « Volume / Speed »

This function can be used to automatically adjust the volume level according to the vehicle speed. Press "Volume / Speed", then adjust the sensitivity or deactivate it by pressing directly on the "Volume / Speed" level bar.

### « Normalise volume »

This function can be used to maintain a constant sound volume from one audio source to another.

### "harman kardon" audio system

If the vehicle is equipped with the "harman kardon" audio system, you can access additional settings:

- activate/deactivate the "Subwoofer" and gain adjustment;
- additional musical equaliser;
- ...

The "Subwoofer" mode optimises sound elements to create an immersive audio experience within the vehicle.

## PAIR AND CONNECT A PHONE

### Pairing, unpairing a telephone





For safety reasons, carry out these operations when the vehicle is stationary.

#### Introduction

This function enables your phone to be paired with the multimedia system.

You can access the "Pair new device" menu from:

- the "Phone" Menu , press "Connect using Bluetooth®" (if a paired phone is not present);
- the "Applications" Menu , then "Devices Manager";
- the "Vehicle" Menu , "Settings", then "Bluetooth®";
- the "Phone" Menu , press the "Settings" icon , then "Devices Manager" (if a phone is already paired);

- the "Audio" Menu , press "Connect using Bluetooth®" (if a paired phone is not present);
- the notification centre, the "Settings" icon , then "Bluetooth®".

**Note:** if no phone is connected to the multimedia system, some menus are disabled and the system offers to connect a phone.

Pairing your telephone will enable the multimedia system to access your telephone functions. No copies of your contacts or personal data will be saved in the multimedia system.

To enable the multimedia system to manage phones equipped with "dual SIM", configure your phone to use a defaultSIM. Please see your phone user manual.

#### Note:

- before pairing, ensure that your phone's Bluetooth® is activated and set its status to "visible";
- the vehicle must be stationary in order for a phone to be paired.

#### Pairing a phone

To use your hands-free system, pair your Bluetooth® phone with the multimedia system.

For more information on activating the visible status of your phone, please refer to your telephone user manual.

Your phone may ask for authorisation to share your contacts, call logs, messages, etc. Accept sharing if you wish to access this information on the multimedia system.

From the "Phone" Menu , then "Connect using Bluetooth®" or the

"Applications" Menu , then "Devices Manager", from your multimedia system:

- a message is displayed on the screen offering to pair a phone;
- press "Pair new device". The multimedia system searches for nearby telephones that have Bluetooth® activated and are visible;
- select your phone from the list of suggestions or select the multimedia system from your phone.

A message appears on the multimedia system screen as well as on the phone, inviting you to accept the pairing request if the proposed code is identical between the phone and the multimedia system.

Once your phone is paired to the multimedia system, you can select the services that you wish to use via the "Devices Manager". For more informa-

## PAIR AND CONNECT A PHONE

tion, please refer to "Connecting, disconnecting a telephone" ➔ 54.

**Note:** the phone is linked to the profile used when pairing. The phone may be unavailable on other user profiles.

### Pairing another telephone

4

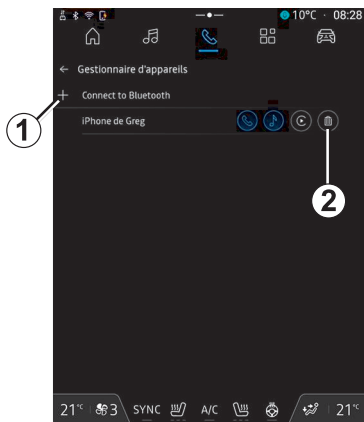

From the "Devices Manager" application you can pair a new phone to the multimedia system:

- press the icon **1** "Pair new device";
- select your new phone from the list of suggestions, then finalise the pairing procedure.

You can also add a new phone from

the "Vehicle" menu  "Settings", "Bluetooth®", "Pair new device", then

select your new phone from the list of suggestions and finalise the pairing procedure.

Your new phone is now paired to the multimedia system.

You can pair up to six phones simultaneously (telephones used only via wired replication Android Auto™ or CarPlay™ appear in addition on the "Devices Manager"). Beyond that, it is recommended to manually unpair the phone of your choice before pairing a new one. Otherwise, the "Devices Manager" will automatically replace the device with the earliest date of use.

### Unpairing a telephone

From the "Devices Manager" menu you can unpair the phone from the multimedia system:

- press the icon **2** of the phone to unpair;
- press "Yes" to confirm.

### Connecting, disconnecting a telephone



For safety reasons, carry out these operations when the vehicle is stationary.



Certain features are only available while the vehicle is stationary.

### Connecting a telephone

To connect a telephone, it must be paired beforehand. For more information, please refer to the section on "Pairing, unpairing a telephone" ➔ 53.

**Note:** if no telephone is connected to the multimedia system, some menus will be deactivated.

Connecting your telephone will enable the multimedia system to access your telephone functions. No copies of your contacts or personal data will be saved in the multimedia system.

To enable the multimedia system to manage phones equipped with "dual SIM", configure your phone to use a default SIM. Please see your phone user manual.

### Automatic connection

Once started, the multimedia system searches for any paired phones with Bluetooth® activated nearby (up to 10 metres away). The system automatically displays the data of the phone connected (phonebook, music, etc).

## PAIR AND CONNECT A PHONE

**Note:** when your phone is connected automatically to the multimedia system, the display of data (phonebook, SMS, contacts, etc.) will only be enabled if you previously allowed data sharing when pairing your phone to the multimedia system. For more information, please refer to the section on "Pairing, unpairing a telephone" → 53.

### Manual connection

You can manually connect/disconnect your phone to/from the multimedia system using the "Bluetooth®" menu, which can be accessed from:

- the "Vehicle" Menu , "Settings", then "Bluetooth®";
- the notification centre, "Settings" , then "Bluetooth®".

From the "Bluetooth®" menu, select "Paired devices" to display a list of paired phones.

Select the services and the phone that you wish to connect and make sure it has Bluetooth® activated.

**Note:** if a call is ongoing while the telephone is being connected, it will automatically be transferred to the vehicle loudspeakers.

### Manage service data

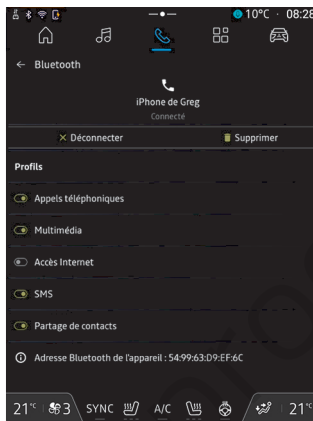

To access your phone directory, music and internet connection directly via the multimedia system, you must authorise service data sharing from the "Profiles" of your "Paired devices", available on the "Bluetooth®" menu. Press the name of the "Paired device", then activate/deactivate the services that you wish to use:

- "Phone calls": make and receive calls;
- "Multimedia": access your music;
- "Internet access": access internet connection sharing by Bluetooth® (please refer to the section on "System settings" → 99);
- "SMS": send and receive SMS;

- "Contact sharing": access the phonebook and call log;
- ...

**Note:** if the service is highlighted, this indicates that it is activated.

 When you use the "Internet access" service, to speed up data transfers you can also use your phone's internet connection via "Access point and connection sharing" WIFI (subject to charges and limitations imposed by your mobile operator).

4

### « Devices Manager »

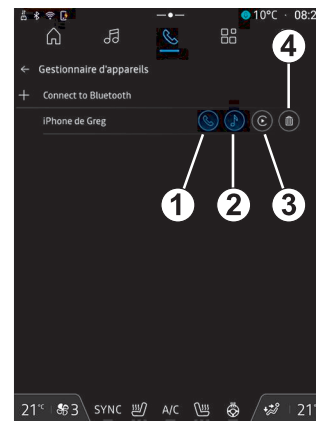

## PAIR AND CONNECT A PHONE

The device manager is used to manage connected phone services. It is best to use the "Devices Manager" app



to manage these services.

4

From the "Applications" Menu , then "Devices Manager", select your phone from the list of suggestions then select the telephone functions that you would like to activate/deactivate:

- « Phone » **1** ;
- "Music" **2**;
- smartphone replication application **3**;
- unpairing the phone **4**.

### Note:

- if the service icon is highlighted, this indicates that it is activated;
- Some phones may allow automatic data transfer.

You can also access the "Devices Manager" from the "Devices Manager" icon available in the "Phone" widget of

the "Home screen" Menu .

### Changing a connected telephone

From "Devices Manager", select the services to connect to another phone that is already paired and present in the list of devices.

**Note:** to change the connected telephone, you will first have to pair more than one telephone.

### Disconnect a phone

From the "Applications" Menu , "Devices Manager" then tap the highlighted service icon of the phone you want to disconnect:

- « Phone » **1** ;
- "Music" **2**;
- smartphone replication application **3**.

You can also disconnect the phone from the "Bluetooth®" menu: select "Paired devices", then press "Disconnect".

**Note:** if a call is in progress when the phone is disconnected, the call will be automatically transferred to your phone.

# CALL MANAGEMENT

## Phone call

### "Telephone" Menu

From the "Phone" Menu .

**Note:** in order to make a call, your telephone must be connected to your multimedia system. For more information, please refer to "Connecting, disconnecting a telephone" → 54.

### Making a call

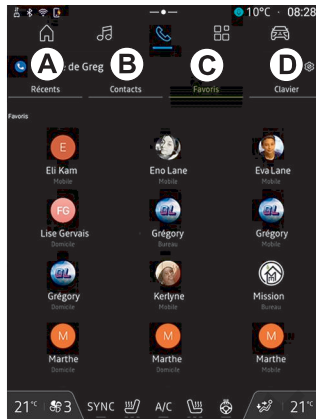

You can make a call by selecting:  
– a number from the call log, by accessing the "Recent calls" tab **A**;

- a contact in the phonebook from the "Contacts" menu **B**;
- a contact in the favourites from the "Favourites" menu **C**;
- the keys on the number keypad from the "Keyboard" menu **D**.

### "Call in progress" screen

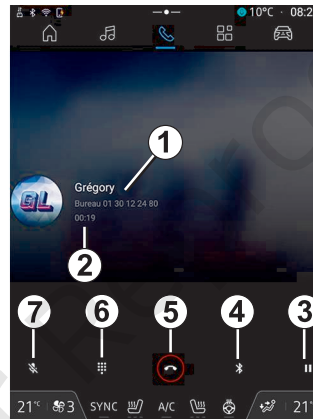

1. Contact name and telephone number.
2. Duration of current call.
3. Put current call on hold.
4. Transfer the call to the phone.
5. Hang up.
6. Access the keypad to dial a number.

7. Deactivate/activate the microphone.

### Receiving a call

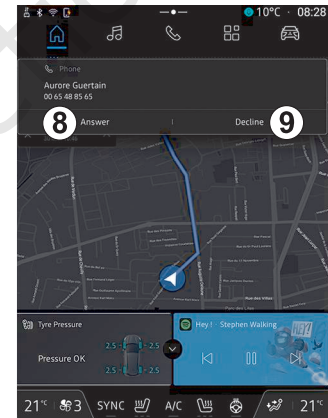

4



## CALL MANAGEMENT

When receiving a call, the "Calls received" screen is displayed and it shows the following information:

- the name of the contact (if the number is present in the list of favourites number or in your phonebook);
- the caller's number (if the number is not present in your phonebook);
- "Private number" (if the number cannot be shown).

4

### "Answer"

To answer a call, press the control **10** on the steering wheel or on the "Answer" button **8** on the multimedia system screen.

### "Reject" a call

To reject an incoming call, press twice on the steering wheel control **10** or press the "Reject" button **9** on the multimedia system screen.

The person calling you will be redirected to your voicemail.

### During a call



During a call you can:

- adjust the volume using the control buttons on the steering column or using the volume buttons on the multimedia screen;
- end a call by pressing "End call" **5** or by pressing button **10** on the steering wheel;
- place a call on hold by pressing button **3**. To resume the call, press button **3** again;
- transfer the call to the connected phone by pressing the "Transfer to phone" button **4**;
- answer a second call and switch between two calls by pressing **11**;

**Note:**

- as soon as you answer the second incoming call, the first call will be put on hold automatically;
- during a call, you can receive a second call but you cannot make a second call;
- access the digital keypad by pressing the "Keyboard" button **6**;
- deactivate/activate your microphone by pressing the "Mute" button **7**.

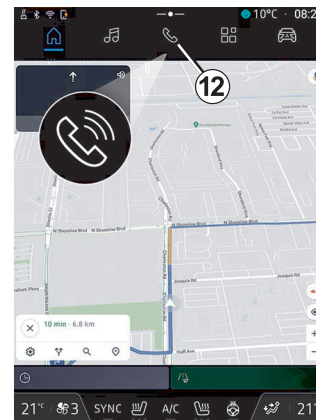

During a call, you can change the World without ending the call in progress.

To return to the "Phone" Menu , press **12**.

## CALL MANAGEMENT

### End a call

To end the call in progress, hang up by pressing the control **10** on the steering wheel or the "End call" button **5** on the multimedia system screen.

### Phonebook





For safety reasons, carry out these operations when the vehicle is stationary.

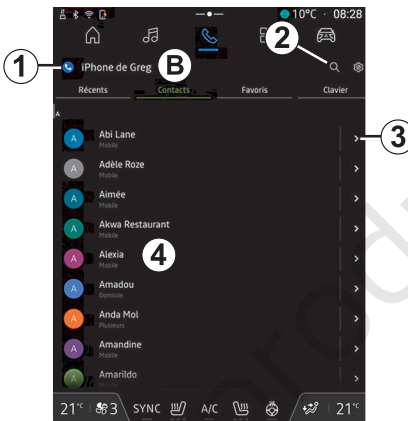

Certain features are only available while the vehicle is stationary.

### "Phonebook" menu



From the "Phone" Menu , press the "Contacts" tab **B** to access your phonebook via your multimedia system.

To enable the multimedia system to manage phones equipped with "dual SIM", configure your phone to enable the multimedia system to access the correct phonebook on the phone.

1. Telephone connected.
2. Search for a contact by name or number.
3. Detailed contact information.
4. List of contacts in the connected phone.

### Downloading the phone memory

By default, when connecting a telephone, the contacts are synchronised automatically if hands-free connection is activated. For more information, please refer to "Connecting, disconnecting a telephone" → **54**.

**Note:** to access the phonebook via the multimedia system, you will need to authorise data sharing on your telephone. Refer to the "Pairing, unpairing a phone" section → **53** and your phone user manual.

### Contacts "Favourites"

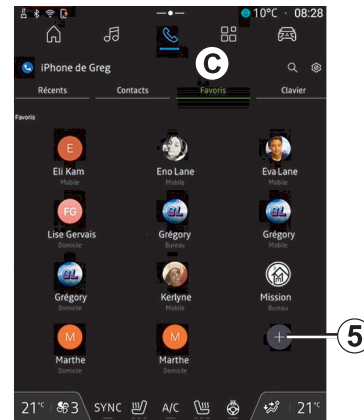

From the "Phone" Menu , press the "Favourites" tab **C** to access the

4

## CALL MANAGEMENT

contacts saved in the phone favourites or add manually from the multimedia system "Contacts" list.

### Add a contact "Favourites"

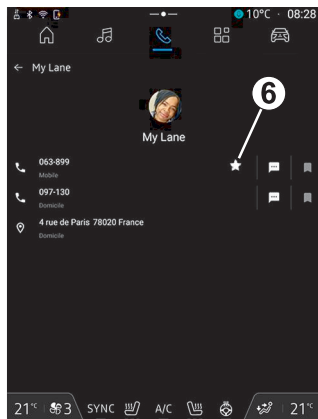

Press "Add a favourite" **5** to add a contact to the "Favourites" list, then follow the instructions displayed on the multimedia screen.

You can also add a favourite number for the contact by selecting the star **6**.

### Searching contacts

You can search for a contact by entering their name or phone number.

Press the magnifying glass **2**. Enter some of the numbers or letters of the

desired contact using the digital keypad which appears on the screen. The phonebook displays the list of contacts starting with the first letter entered.

### Confidentiality

No copies of your contacts or personal data will be saved in the multimedia system.

For reasons of confidentiality, each downloaded contacts list can only be viewed when the corresponding telephone is connected.

### Call log

#### Access the "Recent calls" history

From the "Phone" Menu , press the "Recent calls" tab **A** to access the history of all your calls.

The call log is displayed from the most recent to the oldest.

### "Recent calls" menu

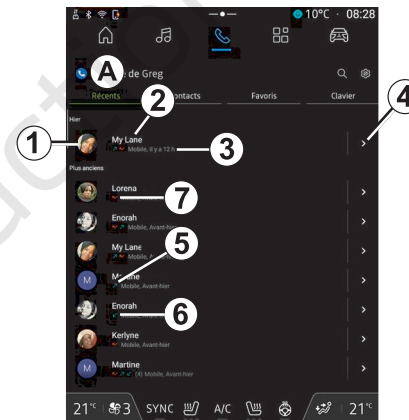

1. Number label.
2. Contact name or phone number.
3. Call time/date.
4. Access contact details.
5. Outgoing call (green upwards arrow).
6. Incoming call (green downwards arrow).
7. Missed call (red arrow).

**Note:** depending on the multimedia screen, some information may not be available.

## CALL MANAGEMENT

### Browsing the call log

Swipe the screen up or down to scroll through the list of calls.

### Making a call from the call log

Press one of the contacts or numbers to call. The call will be started automatically.

### Dial number



For safety reasons, carry out these operations when the vehicle is stationary.



1. Number dialled.
2. Delete the numbers.
3. Contacts suggestion.
4. Call.
5. Digital keypad

### Access "Keyboard"

From the "Phone" Menu , press the "Keyboard" tab **D**.

### Making a call by dialling a number

From the "Keyboard" tab **D**, dial the number using the keypad **5** then press button **4** to start the call.

From the moment the first entry is made, the multimedia system suggests a list of your contacts with the same series of numbers **3**.

Select the contact that you wish to call, then press button **4** to start the call.

### Enter a number using voice control

You can dictate a number using the voice control included with your multimedia system. To do this, start the voice command then, after the beep, state:

– "Call", then dictate the phone number that you wish to call;

or

– "Call" followed by the name of the contact that you wish to call.

The multimedia system displays the number provided and begins to call it.

**Note:** if your contact has several phone numbers (work, home, mobile, etc.), you can make a choice. For example: "Call - Grégory - home".

For more information on the voice command, refer to the section on "Using voice recognition" → 22.

## SMS



Depending on the make and model of your phone, certain functions may not work.

4

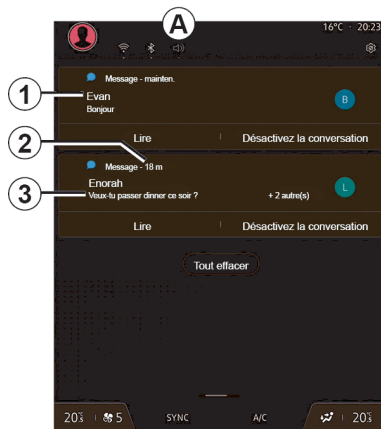

1. Name/number of the sender of the message.

2. Time received;

3. Start of the message.

**Note:** previewing messages is not allowed while driving.

### Access the "SMS"

From the notification centre **A**, you can access your telephone SMS received via the multimedia system.

Your telephone must be connected to the hands-free phone system. You must also authorise the transfer of messages (using your phone settings, depending on the model) in order to use all of its functions.

**Note:** depending on the equipment level, only SMS received during driving can be read by the multimedia system.

### Receiving SMS

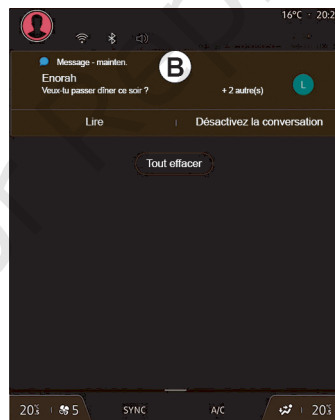

The multimedia system informs you that a new SMS has been received,

via a warning message at **B** that is shown in any menu that is open.

By default, after pairing and the telephone connection, when a new message is received, it will be available on the multimedia system.

### Note:

- only the messages received after pairing and during connection of the telephone to the multimedia system will be available;
- if the notification is deleted or the conversation is disabled, it is no longer possible to access the message on the multimedia system.

### Reading SMS

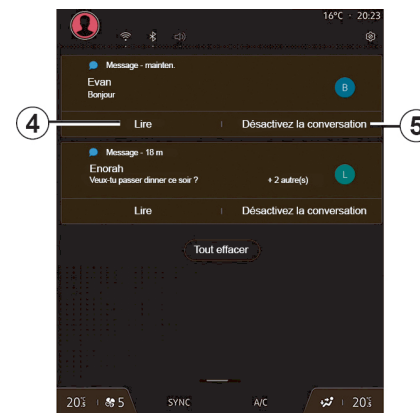

## SMS

The multimedia system enables you to have the SMS read by a voice synthesiser by pressing the "Play" button **4**, then respond to them.

You can deactivate the conversation and stop the notifications by pressing the button **5**.

To stop the SMS from being read, say "Ok Google Stop".

### Responding to SMS

The multimedia system enables you to respond to SMS using only voice recognition.

For more information on the voice command, refer to the section on "Using voice recognition" → **22**.

## PHONE SETTINGS



For safety reasons, carry out these operations when the vehicle is stationary.

4



These features are only available while the vehicle is stationary.

### "Settings" menu

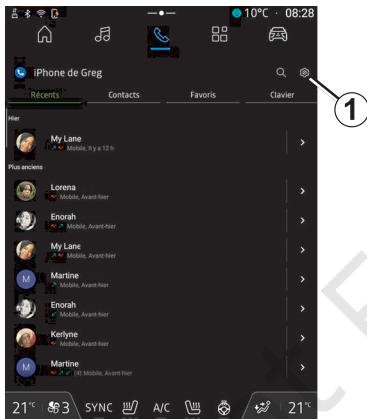

With the phone connected to the system, from the "Phone" Menu ,

press the "Settings" icon  1.

From the "Settings" menu you can access the following settings:

- "Telephone connected";
- "Active call";
- "Confidentiality";
- "Home screen";
- "Contact list order";
- « Devices Manager » ;
- "Bluetooth® settings".

### "Home screen"

This setting can be used to select the tab which will be displayed when the

"Phone" Menu  home screen is launched:

- "Recent" (default);
- "Contacts";
- « Favourites » ;
- « Keyboard ».

### "Contact list order"

This setting can be used to display contacts in alphabetical order, categorised by:

- "First name";
- « Name ».

**Note:** the selection will take effect the next time the multimedia system is restarted.

### "Phone ringtone"

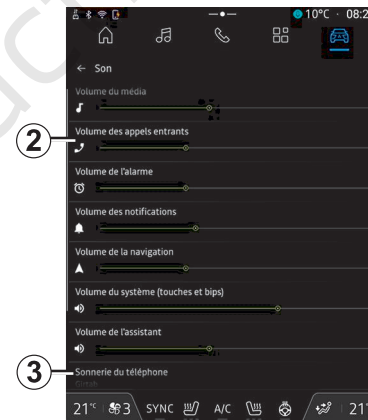

From the "Vehicle" Menu , press the "Settings" menu, then "Sound" to:

- adjust the "Incoming call volume" 2 ;
- select the type of "Phone ringtone" 3 .

For more information, please refer to the "System settings" section ➔ 99.

## WIRELESS CHARGER

### Induction charging area

**i** It is essential not to leave any objects (USBdrive, SD card, starting card, credit card, jewellery, keys, coins, etc.) in the induction charging zone **1** when charging your phone. Remove any magnetic cards or credit cards from the phone case before positioning your telephone in the induction charging area **1**.

**i** Objects left in the induction charging area **1** may overheat. It is advisable to place them in the other storage areas provided. (storage compartment, sun visor storage compartment, etc.)

**i** This system is optional equipment and may not be fitted to all models



The induction charging area **1** can be used to charge a telephone without a cable.

If the vehicle is equipped, the charging area is indicated by (depending on the vehicle):

- an associated symbol; and/or
- the charging status is automatically displayed on the screen as long as the phone is positioned in the dedicated area.

Its location may vary depending on the vehicle. Please refer to the vehicle user manual for further information.

**Note:**

- the induction charging is initiated when the ignition is switched on or when the engine is on;
- ensure that your phone is compatible with inductive charging. For more details on the list of compatible phones, please contact an approved dealer;
- to enable optimal charging, it is preferable to remove the protective case from your phone before charging;
- for optimal charging, the entire surface of the smartphone should coincide with a maximum of the surface of the charging area and be positioned the most central possible.

### Charging procedure

Place your phone in the induction charging zone **1**. Charging is automatically started and the charging progress **2** is displayed on the screen.

The charging procedure may be interrupted if an object is detected in the induction charging area **1** or if the induction charging area **1** is overheating. Once the temperature has dropped, your phone will soon start to charge again.

## WIRELESS CHARGER

### Charging progress

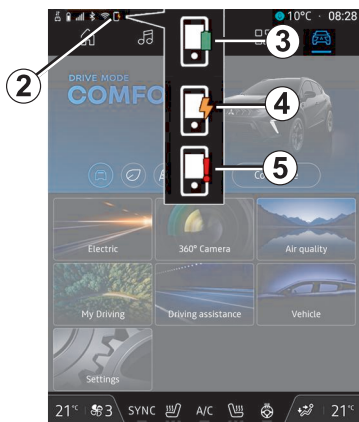

4

The multimedia system informs you of your phone's charging status **2**:

- charging complete **3**;
- charging in progress **4**;
- object detected in the charging area/object overheating/charging procedure interrupted **5**.

**Note:** the multimedia system will inform you if the phone charging procedure is interrupted.

Depending on the equipment, an colour indicator light located near the charging zone also informs you of the charging status:

- green when charging is complete;
- yellow when charging is in progress;

- flashes in yellow when a metal object is detected in the induction charging area;
- flashes in yellow, accompanied by a message on the multimedia screen, when the car is stopped and the driver opens the door;
- yellow or green switched off, accompanied by a message on the multimedia screen, when the charging zone temperature is too high.

# ANDROID AUTO™ , CARPLAY™

## Smartphone replication

**i** When you use the "Android Auto™" app or the "CarPlay™" service, you are using your smartphone's internet connection (subject to charges and limitations imposed by your mobile operator).

**i** The "Android Auto™" app and the "CarPlay™" service functions may vary depending on the make and model of your smartphone. For further information, please refer to the manufacturer's website if there is one.

Android Auto™ 

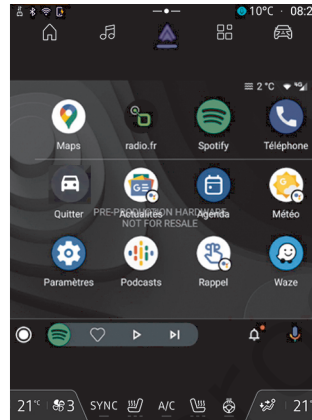

CarPlay™ 

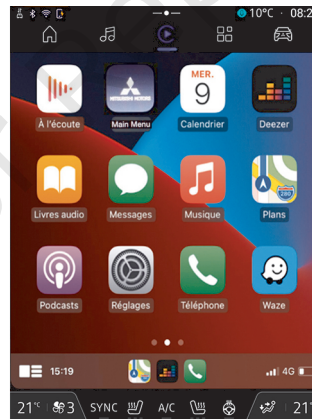

This function enables you to replicate your smartphone in order to use some of its apps and functions on the multimedia system screen, via:

- « Android Auto™ »  ;
- « CarPlay™ » .

**Note:** when you use "Android Auto™" or "CarPlay™", you can access your smartphone's navigation and music apps.

These applications will replace similar applications integrated into your multimedia system which are already running.

Only one navigation system can be used among:

- « Android Auto™ » ;
- « CarPlay™ » ;
- the one included in your multimedia system.

**Note:** when you are using the "Android Auto™" application or the "CarPlay™" service, certain multimedia system functions will continue to run in the background. For example, if you start "Android Auto™" or "CarPlay™" and use the navigation on your smartphone while the radio on the multimedia system is currently playing, the radio will continue to be broadcast.

# ANDROID AUTO™ , CARPLAY™

## Introduction Android Auto™

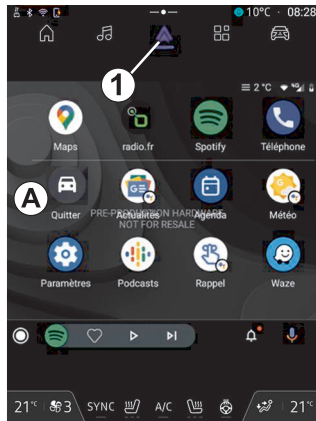

5

"Android Auto™" is an app that enables you to replicate your smartphone on the screen of your multimedia system.

### Note:

- the "Android Auto™" app only works if your smartphone is connected to your vehicle's USB port or wirelessly by Bluetooth® to enable automatic WIFI connection to your system;
- to ensure that the app functions correctly, it is advisable to use USB cables recommended by the smartphone manufacturer.

## First use

If you haven't done already, download and install the "Android Auto™" app via your compatible smartphone's app download platform.

Connect your smartphone to your multimedia system USB port or connect it using Bluetooth® to automatically initiate the WIFI connection.

Accept the requests on your smartphone in order to use the application.

**Note:** you can check the compatibility of your smartphone and its version of Android using the "Android Auto™" service: consult the Google® documentation.



The multimedia system suggests that you use the "Android Auto™" service.

The application is launched on the multimedia system and should be visible from area **A**. Smartphone replication replaces the "Phone" Menu 

and the **1**  icon appears.

If the procedure described above fails, repeat the operation.

Once used for the first time, smartphone replication will launch automatically for further sessions.

From the "Applications" Menu , then "Devices Manager", you can also activate/deactivate the smartphone replication function by pressing the "Android Auto™" replication icon. 

## Exit replication

To exit "Android Auto™" wireless replication:

- press "Exit car mode" on the your smartphone notifications screen;
- deactivate the smartphone replication by pressing the "Android Auto™"

replication icon  or activate the

"Phone" service  from the "Devices Manager";

- select the approved dealer's app among the smartphone replication apps.

# ANDROID AUTO™ , CARPLAY™

## Introduction CarPlay™

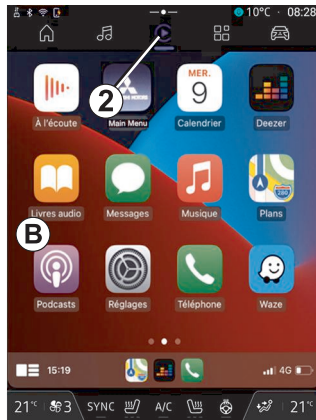

"CarPlay™" is a pre-installed service on your smartphone which enables you to use some apps on your smartphone via your multimedia system screen.

### Note:

- the "CarPlay™" service only works if the SIRI service is activated, if the vehicle microphone is activated and if your smartphone is connected to your vehicle's USB port or wirelessly using Bluetooth® to enable automatic connection to your system by WIFI;
- to ensure that the app functions correctly, it is advisable to use USB cables recommended by the smartphone manufacturer.

## First use

Connect your smartphone to your multimedia system USB port or connect using Bluetooth® to enable automatic WIFI connection to your system.



The multimedia system suggests that you:

- authorise the connection and data sharing;
- automatically connect to the "CarPlay™" service for future sessions.

**Note:** if you do not allow the multimedia system to remember these choices, a reminder message will be displayed each time you start.

Accept the requests on your smartphone in order to use the application.

The service is launched on the multimedia system and should be visible from area **B**. Smartphone replication

replaces the "Phone" Menu  and the 2  icon appears.

If the procedure described above fails, repeat the operation.

From the "Applications" Menu , then "Devices Manager", you can also activate/deactivate the smartphone replication function by pressing the

"CarPlay™" replication icon .

## Exit replication

To exit "CarPlay™" wireless replication:

- deactivate the WIFI on your smartphone;
- deactivate the smartphone replication by pressing the "CarPlay™" replic-

ation icon  or activate the

"Phone" service  from the "Devices Manager";

- select the approved dealer's app among the smartphone replication apps.

## Voice recognition



5

## ANDROID AUTO™ , CARPLAY™

Press and hold the control **3** to activate/deactivate your smartphone's voice recognition function for controlling certain apps and functions by voice command.

For more information, see the section on "Using voice recognition" ➔ **22**.

### Android Auto™

5



Using "Android Auto™" replication, you can also command some of the functions on your smartphone:

- by pressing the voice recognition button **4**;
- by stating the "Ok Google" or "Hey Google" voice command.

### CarPlay™

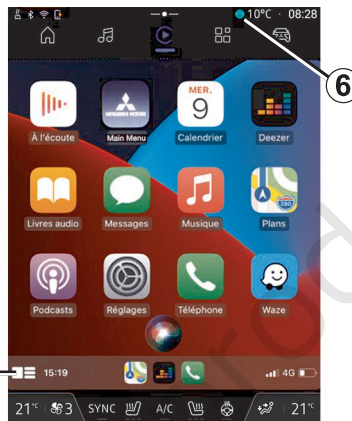

Using "CarPlay™" replication, you can also command some of the functions on your smartphone:

- by pressing and holding button **5**;
- by stating the "Dis Siri" or "Say Siri" voice command, if the vehicle's microphone is activated **6**.

# APP MANAGEMENT

## "Applications" Menu



For safety reasons, carry out any adjustments while the vehicle is stationary.



Some settings are only available while the vehicle is stationary.

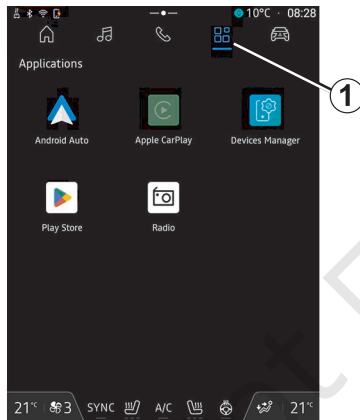

From the "Applications"  1, you can access:

- the apps installed on your multimedia system;
- smartphone replication;
- "User manual";
- "Devices Manager";
- "Play Store™";
- ...

**Note:** some services will be available free of charge for a trial period.

You can download new apps via the "Play Store™" app.

## "Applications" menu

You can access the apps installed on your multimedia system.

The two first lines are dedicated to apps pre-installed by default.

Any other apps downloaded from the "Play Store™" will be listed in alphabetical order.

If the app is not available, it will not be displayed.

Press the app to open it.

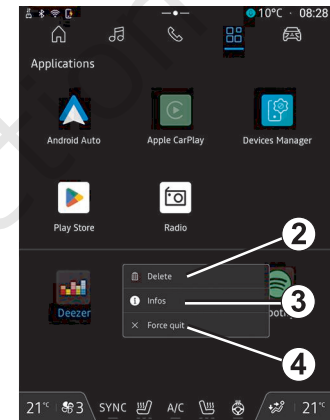

By pressing and holding the app, you can:

- "Delete" the app 2;
- access information on the app 3 (version, validity or creation date, title, etc.);
- force the app to close 4.



**Note:** only apps installed from the "Play Store™" can be deleted.

## "Applications" settings

You can access the "Applications" information and settings from the "Settings" menu via:

- the "Applications" Menu , then the "Settings" app;

## APP MANAGEMENT

- the "Vehicle" Menu , then "Settings";
- the notification centre, then the "Settings" icon .

### Location of the "Applications"

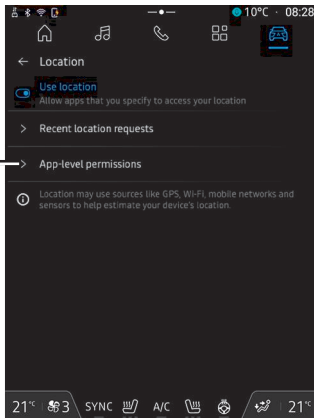

From the "Settings" menu, select "Location", then "App permissions" **5** to configure the location permissions for the apps installed on your multimedia system.

### "Apps and notifications"

From the "Settings" menu, then "Apps and notifications", you can access information and settings for

the "Applications" installed on your multimedia system:

- "Display all apps";
- "Default apps";
- "App permissions";
- "Specific access rights granted to apps".

### "Display all apps"

You can access information on all the apps present in your multimedia system:

- title of apps;
- size of apps;
- version of apps;
- app validity or creation date;
- ...

### "Default apps"

You can access the default apps used for:

- the home screen;
- assistance;
- the SMS;
- the telephone;
- the navigation system.

You can also configure the opening of the app access links.

### "App permissions"

You can access the app usage permissions for the following purposes:

- "Physical activity";
- "Calendar";
- "Camera";
- "Body sensors";
- "Contacts";
- ...

### "Specific access rights granted to apps"

You can activate/deactivate the specific access rights granted to apps used for:

- "Changing the system settings";
- "Accessing notifications";
- "Accessing premium SMS";
- "Accessing user information";
- "WIFI control".

5

# VEHICLE LOANING AND RELINQUISHING

## Vehicle lending

### Legal information

When you lend your vehicle, you are obliged (see the General Conditions of Sale of the connected services) to inform the person to whom you are lending your vehicle that the vehicle will be connected and collecting personal information such as the vehicle's location.

### Data collection

The collection of vehicle data may be temporarily suspended.

To do this, when the vehicle is started and the "Security and Confidentiality" window is displayed on the centre screen, select "OFF" to suspend data collection.

The services will be disabled, except for the functions that are required or related to safety such as the automatic emergency call in the event of an accident.

## Vehicle relinquishment

When relinquishing the vehicle, you must inform the new buyer that this vehicle is connected and collects personal data such as the vehicle's location.

### Deleting personal data

When the vehicle is relinquished (e.g. resale, purchase), it is essential to delete all personal information stored within and outside the vehicle.

To do this, reset the on-board system and delete the vehicle from your account.

### Resetting the system

When the vehicle is relinquished, the seller must reset the system. To do this, switch on your vehicle's multimedia system.

From the "Vehicle" Menu , "Settings", "System", "Resetting options", then "Restore factory settings" (delete data).

**Note:** it is only possible to reset the system from the administrator profile.

## DRIVING AIDS

### "Driving assistance" menu



These functions provide additional driving aids. Therefore, under no circumstances can they replace the driver's vigilance and responsibility (the driver must always be ready to brake).



For safety reasons, carry out any adjustments while the vehicle is stationary.



Some settings have to be modified while the engine is on in order for them to be stored by the multimedia system.

### Introduction

The vehicle is equipped with driving aids that offer additional assistance when driving your vehicle.

Please refer to the vehicle user manual for further information.

**Note:** some "Driving assistance" settings are available while the vehicle is stationary.

### Access the "Driving assistance"

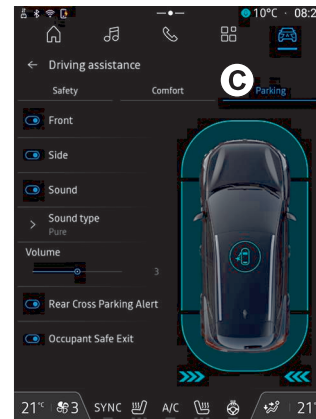
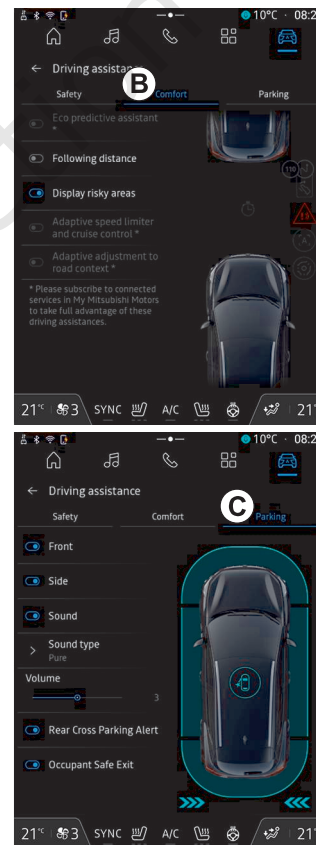
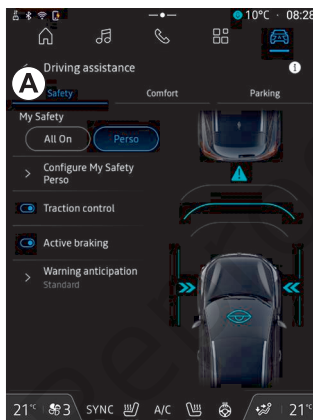

From the "Vehicle" Menu , select "Driving assistance" then the "Security"

## DRIVING AIDS

tab **A** for safety-related driving aids or the "Comfort" tab **B** for comfort-related driving aids.

The "Parking" tab **C** is intended for parking aids.

For more information on the "Parking" tab **C**, please refer to the section on "Parking aids") ➔ 79.

### « Security »

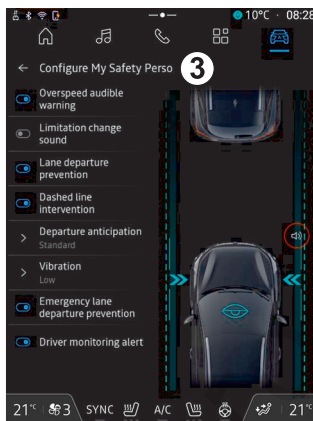

Using the "Security" tab **A**, you can activate/deactivate and/or configure the safety-related driving aids:

- "All on" **1**;
- « Perso » **2** ;
- « Configure My Safety Perso » **3** ;
- « Overspeed sound warning » ;
- « Limitation change sound » ;
- « Lane departure prevention » ;
- "Operations on broken lines";
- « Departure anticipation » ;
- « Vibration » ;
- "Emergency lane departure prevention";
- « Blind spot warning » ;
- « Driver monitoring alert » ;
- « Active braking » ;

- « Warning anticipation » ;
- « Pedestrian detection » ;
- « Pedestrian warning sound » ;
- « Blind spot warning » ;
- ...

**Note:** the activate/deactivate button is highlighted when the function is activated.

### "My Safety"

#### "All on" **1**

When My Safety "All on" is activated, all your safety aids are activated. This mode is activated by default each time the vehicle is started.

The My Safety "All on" function can also be activated by pressing your vehicle's  control once.

For more information on the  control, please see the "My Safety" section in your vehicle user manual.

#### « Perso » **2**

When the My Safety "Perso" function is activated, the safety aids that you have configured and customised using "Configure My Safety Perso" **3** are enabled.

## DRIVING AIDS

The My Safety "Perso" function can also be activated by pressing your vehicle's  control twice.

For more information on the  control, please see the "My Safety" section in your vehicle user manual.

### « Configure My Safety Perso » 3

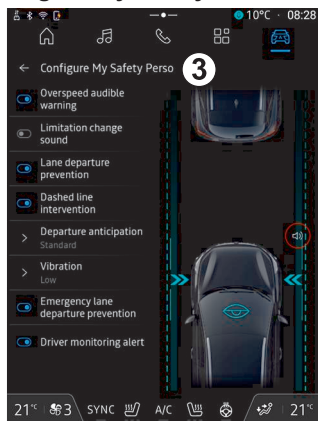

From this menu, you can select and/or configure the functions that you want to enable when you activate My Safety "Perso":

- « Overspeed sound warning » ;
- « Limitation change sound » ;
- « Lane departure prevention » ;
- "Operations on broken lines";
- « Departure anticipation » ;

- « Vibration » ;
- "Emergency lane departure prevention";
- « Blind spot warning » ;
- « Driver monitoring alert » ;
- ...

### « Overspeed sound warning »

This function warns the driver with an audible alert when the vehicle exceeds the authorised speed limit.

### « Limitation change sound »

This function warns the driver by an audible alert when the authorised speed limit changes.

### « Lane departure prevention »

This function enables vibrations on the steering wheel (or by an audible warning, depending on equipment) to warn the driver if the vehicle strays out of lane and breaches a line (continuous or broken) without the direction indicators having been activated.

For further information, please refer to the "Lane Departure Warning" section in the vehicle user manual.

### "Operations on broken lines"

This function corrects the vehicle's trajectory when it strays out of lane and

crosses a broken line without the direction indicator lights having been activated if there is an imminent risk of impact (e.g. risk of hitting another vehicle when changing lanes without the direction indicator lights having been activated).

You can choose the desired vehicle system sensitivity:

- « Early » ;
- « Standard » ;
- « Late ».

You can also choose the desired vibration intensity:

- « Low » ;
- « Standard » ;
- « High ».

### "Emergency lane departure prevention"

This function warns the driver by vibrations on the steering wheel (or an audible alert, depending on equipment) when the vehicle strays out of lane and breaches line (continuous or discontinuous) without the direction indicator lights having been activated if there is a risk of impact (e.g. risk of hitting another vehicle when changing lanes without the direction indicator lights having been activated).

## DRIVING AIDS

For further information, please refer to the "Lane Departure Warning" section in the vehicle user manual.

### « Blind spot warning »

This function notifies the driver when another vehicle is in their blind spot.

For further information, please refer to the "Blind spot warning" section in the vehicle user manual.

### « Driver monitoring alert »

This function detects any reduction in the driver's reactivity. It takes into account:

- sudden and random movement of the steering wheel;
- frequent activation of the Lane Keeping Assist warning.

This function notifies the driver via a sound warning and by displaying a warning message on the instrument panel advising the driver to take a break.

For further information, please refer to the "Driver vigilance warning" section in your vehicle user manual.

### « Active braking »

From this menu you can activate/deactivate the "Active braking" function. You can also choose the sensitivity of the

warning trigger by pressing "Warning anticipation":

- « Early » ;
- « Standard » ;
- « Late ».

For more information, please see the "Advanced safety" section in your vehicle user manual.

### « Pedestrian detection »

This function detects and warns the driver when there is a risk of collision with a pedestrian.

For further information, please refer to the "Safe passenger exit" section in your vehicle user manual.

### « Pedestrian warning sound »

This feature warns the driver with an audible alert when there is a risk of collision with a pedestrian.

For further information, please refer to the "Safe passenger exit" section in your vehicle user manual.

### « Comfort »

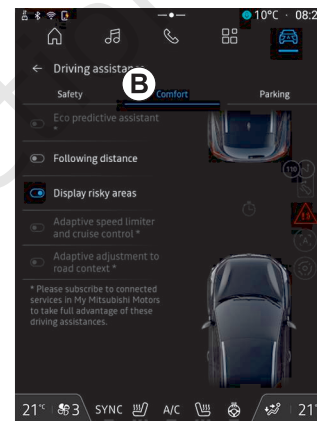

Using the "Comfort" tab **B**, you can activate/deactivate and/or configure the comfort-related driving aids:

- « Sailing » ;
- « Following distance » ;
- ...

**Note:** the activate/deactivate button is highlighted when the function is activated.

### « Sailing »

This function enables a reduction in engine braking during deceleration phases and to go further without accelerating, in order to save fuel.

## DRIVING AIDS

For further information, please refer to the "Driving advice, Eco driving" section in your vehicle user manual.

### « Following distance »

This function notifies the driver if they are too close to another vehicle.

For further information, please refer to the "Safe distance alert" section in your vehicle user manual.

# PARKING AIDS

## Introduction



These functions provide additional driving aids. Therefore, under no circumstances can they replace the driver's vigilance and responsibility (the driver must always be ready to brake).



When manoeuvring, the steering wheel may turn quickly: do not put your hands inside and make sure that nothing is caught inside.



For safety reasons, carry out any adjustments while the vehicle is stationary.

The vehicle is equipped with parking aids that offer additional assistance during parking manoeuvres.

Depending on the equipment, from the

"Vehicle" Menu , press the "Driving assistance" menu, then the "Parking" tab to access the Park Assist menu:

- « Parking assistance » ;
- « Hands-free Park Assist ».

Please refer to the vehicle user manual for further information.

## "Parking assistance" menu

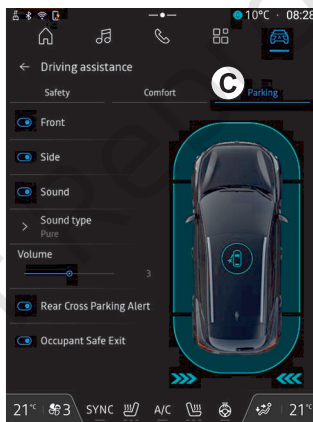

From the "Vehicle" Menu , select the "Driving assistance" menu, then tab "Parking" **C**. Use this menu to access the Park Assist settings. For further information, please refer to the

"Parking assistance" section in your vehicle user manual.



1. « Front ».
2. « Side ».
3. « Sound ».
4. « Sound type ».
5. « Volume ».
6. « Rear Cross Traffic Alert ».
7. « Occupant Safe Exit Assist ».

## "Parking assistance" detection areas

You can activate or deactivate the following Park Assist zones:

- « Front » **1** ;
- « Side » **2**.



## PARKING AIDS

### « Sound » 3

Press "Sound" **3** to activate or deactivate the Park Assist sound warnings.

The following settings can be modified:

- "Sound type" **4**: select the type of audible warning among those offered;
- "Volume": adjust the obstacle detection warning volume using the "Volume" bar **5**.

### « Rear Cross Traffic Alert » 6

The "Rear Cross Traffic Alert" function **6** detects obstacles as they approach the side of the vehicle from behind.

It is activated when reverse gear is engaged and the vehicle is stationary or moving at a low speed.

You will be notified of approaching obstacles by a continuous beep as well as a display on the multimedia screen and a light signal on the rear view mirror.

**Note:** stationary obstacles are not detected.

For more information on the "Rear Cross Traffic Alert" function, please see the section on "Rear Cross Traffic Alert" in your vehicle user manual.

### « Occupant Safe Exit Assist » 7

The "Occupant Safe Exit Assist" warning **7** detects a potential hazard and

warns the driver and/or passenger(s) if they open a door while the vehicle is stationary.

This is activated when the vehicle is parked.

If an obstacle approaches the vehicle, a warning will be displayed on the instrument panel, a light signal will appear on the door mirrors and inside of the doors and a beep will sound.

**Note:** stationary obstacles and pedestrians are not detected.

For more information on the "Occupant Safe Exit Assist" function, please see the section on "Occupant Safe Exit Assist" in your vehicle user manual.



This system is optional equipment and may not be fitted to all models

### "Hands-free Park Assist" menu

The "Hands-free Park Assist" function assists you with parking manoeuvres by taking control of the steering wheel, the brakes, the engine and the gear lever.

Throughout the manoeuvre, follow the instructions shown on the multimedia system screen (eg. "Select reverse gear", "Reverse" etc.) and take your hands off the steering wheel.

You can retake control of the vehicle at any time by operating the steering wheel.

You can access the "Hands-free Park Assist" menu from:

- the "Vehicle" Menu , press the "Driving assistance" menu, then the "Parking" tab **C**;
- the "Hands-free Park Assist" widget by pressing "Open" (to configure, see the "Add and manage widgets" section → **20**);
- via the "Hands-free Park Assist" shortcut in the 360° camera view (for more information, see the "360° Camera" section → **80**);
- the "Favourites" button on the steering wheel (to configure, see the "User settings" section).



From this menu, you can choose the following manoeuvres:

## PARKING AIDS

- parallel parking **9**;
- perpendicular parking **10**;
- moving out of a parallel parking space **11**.

For further information, please refer to the "Hands-free Park Assist" section in your vehicle user manual.

Using the icon **12**, you can select the default manoeuvre type:

- « Parallel parking » ;

or

- « Bay parking ».

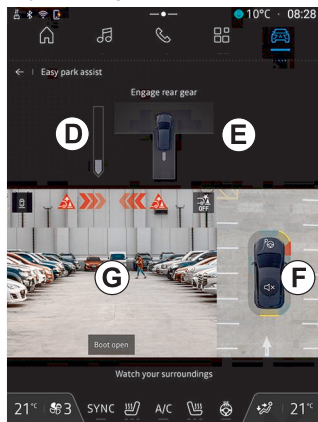

Depending on the equipment, different views are displayed on the multimedia system screen during the manoeuvre:

- gauge indicating the progress of the manoeuvre **D**;

- the manoeuvre direction instructions **E**;
- view of the vehicle, the surrounding environment and available parking spaces **F**;
- front/rear camera view **G**.

If the conditions required for the operation are not met, a warning message is displayed on the screen.

To cancel the current manoeuvre, press "Cancel the manoeuvre".



This system is optional equipment and may not be fitted to all models

## REVERSING CAMERA



For safety reasons, carry out any adjustments while the vehicle is stationary.

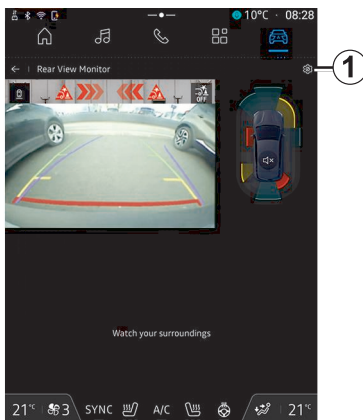

When the reverse gear is engaged, the reversing camera located at the rear of the vehicle is activated in order to transmit the view behind the vehicle to the multimedia screen.

When the reversing camera is displayed on the multimedia screen, you can access the settings by pressing

the "Settings" icon  **1**.

For further information on the reversing camera, please see your vehicle user manual.

### Note:

- make sure that the cameras are not obscured (by dirt, mud, snow, etc.);
- the reversing camera display is no longer available (it is replaced by a black screen) when the vehicle speed is above approximately 6 mph (10 km/h), depending on local regulations.

### "Image settings"

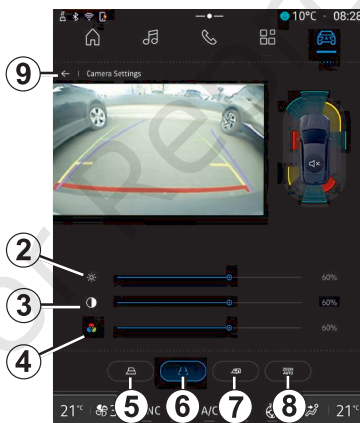

You can adjust the following settings:

- brightness **2**;
- contrast **3**;
- colour **4**.

To exit the settings, press **9**.

### "Guide lines"

You can activate or deactivate:

- the moving guide lines **5** indicating the vehicle's trajectory according to the steering wheel position;
- the fixed guide lines **6** indicating the distance behind the vehicle;
- the trailer's moving guide lines **7** indicating the trailer's trajectory according to the steering wheel position.

### "Auto zoom"

(depending on equipment)

You can activate or deactivate "Auto zoom" **8**.

6

## 360° CAMERA



This function is an additional aid. It cannot, therefore, under any circumstances replace the vigilance or the responsibility of the driver.

The driver should always be ready for sudden incidents while driving: always ensure that there are no small, narrow moving obstacles (such as a child, animal, pushchair, bicycle, stone, post, etc.) in the blind spot when manoeuvring.



This system is optional equipment and may not be fitted to all models



The screen represents an inverted image of the rear views.

The gauges are a representation projected onto flat ground. This information must not be taken into account when superimposed on a vertical object or an object on the ground.

Objects which appear on the edge of the screen may be deformed.

In very bright light (snow, vehicle in sunshine, etc.), the camera vision may be adversely affected.

### Introduction

The vehicle is fitted with four cameras fitted at the front, in the side door mirrors and at the rear of the vehicle to offer you additional aid during difficult manoeuvres.

For further information, please refer to the "360° Camera" section in your vehicle user manual.

**Note:** make sure that the cameras are not obscured (by dirt, mud, snow, etc.).

### Operation

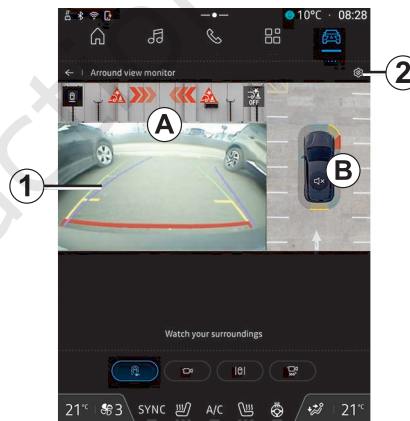

The system can be activated from the

"Vehicle" Menu  by pressing the "360° Camera" menu or by shifting to reverse gear (and up to five seconds after shifting to another gear).

A view of the area around the rear of the vehicle is displayed in zone **A** of the multimedia system screen, accompanied by guide lines **1**, an outline of the vehicle and sound signals.

Ultrasonic sensors installed in your vehicle "measure" the distance between the vehicle and an obstacle.

When the red zone is reached, use the bumper image to stop accurately.

## 360° CAMERA

A bird's eye view of the vehicle and its surroundings is displayed in zone **B** on the multimedia system screen.

You can adjust the "360° Camera" display using the icon **2**.

For further information, please refer to the "360° Camera" section in your vehicle user manual.

### Camera choice

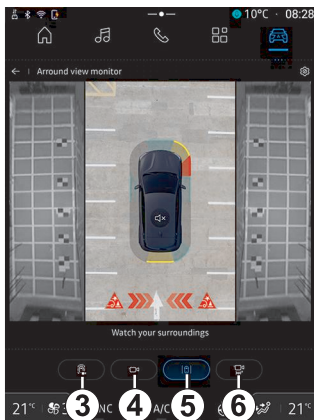

You can also select the type of view to display on the screen:

- standard front/rear view and bird's eye view **3**;
- panoramic front/rear view **4**;
- side views **5**;
- 3D view **6**.

**Note:** the "360° Camera" can be accessed using the "Favourites" button on the steering wheel control.

### Settings

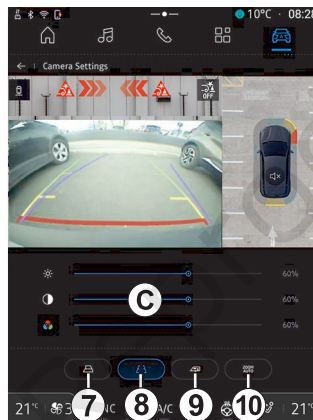

From the "360° Camera" menu, press the camera settings icon **2**. Use this menu to configure the camera:

- press **7** to activate or deactivate the display of the moving guide lines;
- press **8** to activate or deactivate the display of the fixed guide lines;
- press **9** to activate or deactivate the display of the trailer guide lines;
- press **10** to activate or deactivate the automatic zoom;
- move the adjustment bars **C** to set the brightness, contrast and colours of the image.

## DRIVE MODE

### "Drive Mode" menu



For safety reasons, carry out any adjustments while the vehicle is stationary.

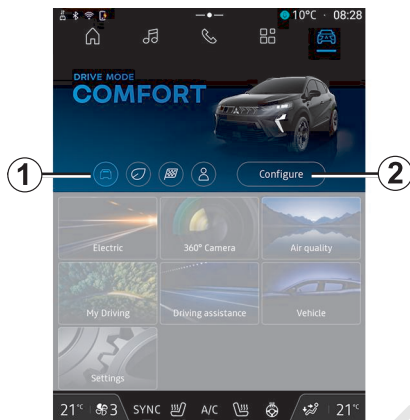

From the "Vehicle"  Menu, you can access "Drive Mode". This menu lets you customise the behaviour of some on-board systems.

### Selecting mode

Available modes may vary according to the vehicle and equipment level. From the "Drive Mode" menu, select the mode **1** desired:

- « Comfort » ;
- « Eco » ;
- « Sport » ;
- « Perso » ;
- ...

For more information on each of these modes, please see your vehicle user manual.

### « Configure »

Press "Configure" **2** to customise the various parameters of the following on-board systems:

- « Steering effort » ;
- « Vehicle dynamics » ;
- « Climate » ;
- « Ambient lighting » ;
- ...

### Note:

- some configuration menus may vary depending on the vehicle and the equipment level;
- you can also access the various modes by pressing your vehicle's "Drive Mode" control repeatedly. Please refer to the vehicle user manual for further information.

### Configure "Drive Mode"

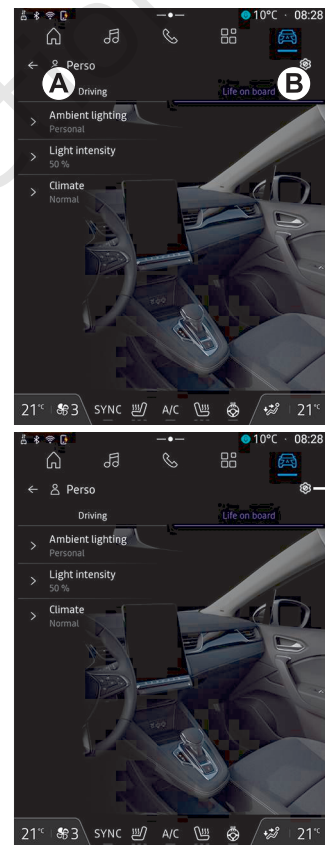

The "Drive Mode" screen of the "Configure" contains the following tabs:

## DRIVE MODE

- "Driving" **A** shows the functions related to driving the vehicle;
- "Life on board" **B** shows the functions related to the vehicle on-board experience.

**Note:** the available settings may vary according to the "Drive Mode" mode, your vehicle model and equipment level.

From the tab **3**, you can "Reset mode settings".

### "Driving" settings

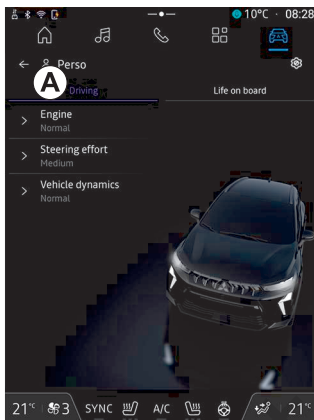

From the "Driving" tab **A**, you can configure the following equipment:

- « Engine » ;
- « Steering effort » ;
- « Vehicle dynamics » ;

- ...

### « Engine »

This menu offers several engine response settings:

- « Normal » ;
- « Sport » ;
- « Eco ».

Depending on the setting selected, the power and engine torque become more noticeable and responsive.

### « Steering effort »

This menu offers several steering response settings:

- « Low » ;
- « Middle » ;
- « High ».

Depending on the setting selected, the steering sensitivity can be adjusted to become more reactive or heavier in order to provide optimal balance between a smooth and accurate steering experience.

### « Vehicle dynamics »

This menu, available on 2-wheel drive vehicles, offers several operation settings:

- « Normal » ;
- « Comfort » ;
- « Sport ».

Depending on the setting selected, the braking of the wheels varies in relation to the angle of the wheels in order to offer optimal trajectory.

### "Life on board" settings

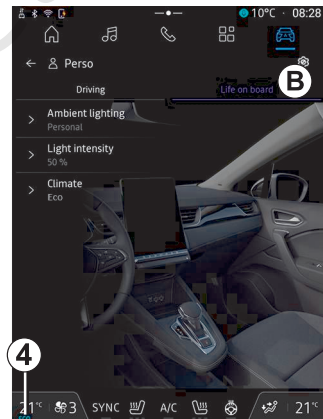

From the "Life on board" tab **B**, you can configure the following equipment:

- « Ambient lighting » ;
- « Light intensity » ;
- « Climate » ;
- ...

### « Ambient lighting »

You can use this menu to set the ambient lighting in the passenger compartment:

## DRIVE MODE

- « Changing » ;
- « Personal ».

For more information on "Ambient lighting", please refer to the "Ambient lighting" section → **88**

### « Light intensity »

You can use this menu to adjust the brightness of the ambient lighting.

For more information on "Light intensity", please refer to the "Ambient lighting" section → **88**.

### « Climate »

You can use this menu to adjust the air conditioning operation:

- « Normal » ;

The "Normal" setting allows you to make optimal use of the air conditioning.

- « Eco ».

The air conditioning "Eco" setting allows you to optimise the vehicle's range by acting on the performance of the air conditioning (e.g. longer time to reach the requested temperature setpoint, etc.).

When the air conditioning "Eco" setting is activated, the ECO indicator light **4** is displayed on the multimedia screen.

## AMBIENT LIGHTING



For safety reasons, carry out these operations when the vehicle is stationary.

From the "Vehicle" Menu , press the "Configure" button in the "Drive Mode" menu, the "Life on board" tab then "Ambient lighting".

Use this menu to set the ambient lighting in the passenger compartment:

- « Changing » ;
- « Personal ».

### « Changing »

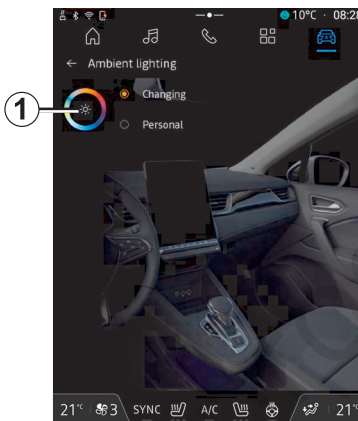

To change the ambient colour gradually, press "Changing".

The multimedia system automatically adjusts the ambient lighting for you in order to obtain an ambient lighting colour most suitable to the time of the day.

### « Personal »

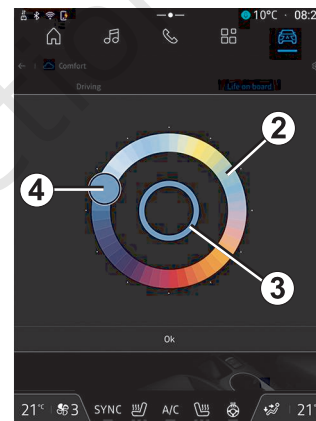

To change your vehicle's ambient lighting colour, press "Personal" then on the icon **1**. Select one of the colours among those offered on the circular palette **2** by moving the button **4**.

The inner circle **3** represents the ambient colour of the multimedia screen and the instrument panel in your vehicle.

Press "OK" to confirm your choice of colour or press "Cancel" to discard the colour selected.

## AMBIENT LIGHTING

### « Light intensity »



You can control the intensity of the ambient lighting.

From the "Vehicle" Menu , press the "Configure" button in the "Drive Mode" menu, the "Life on board" tab then "Light intensity".

Move the cursor **5** on the brightness bar to adjust the ambient lighting brightness.

**Note:** the ambient lighting brightness is stored and associated to the vehicle day or night mode as set when adjusted.

6

## TYRE PRESSURE



For safety reasons, carry out these operations when the vehicle is stationary.



For more information on tyre pressure, please refer to the "Tyre pressure monitoring system" section in the vehicle user manual.

6

From the "Vehicle" Menu , press "Vehicle" then the "Tyre pressure" tab to check the tyre pressure status and reset the "Tyre pressure" monitoring system.

The display on your vehicle's instrument panel informs you of any tyre inflation faults.

### Tyre pressure status with TPW system

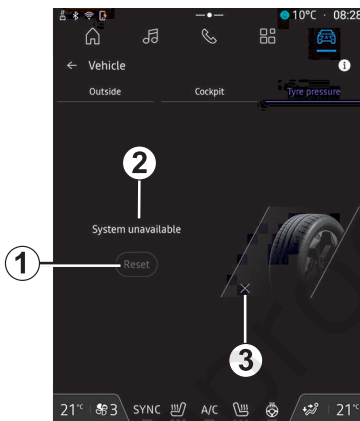

From the multimedia system, you can check the tyre pressure status.

The symbol **3** uses colours to indicate the tyre pressure status:

- green – the tyre pressure is correct or unchanged since the last re-initialisation;
- Orange – the pressure of one of the tyres is insufficient.

For more information on the "Tyre pressure" control system installed in

your vehicle, press the  icon.

Re-initialise the "Tyre pressure" control system at **1**.

The procedure to re-initialise your system is displayed at **2**.

### Reinitialising

This function enables re-initialisation by pressing the "Reset" button **1**.

The resetting procedure must be carried out while the vehicle is stationary and the ignition is switched on.

Start the re-initialisation procedure by pressing "Yes" or return to the tyre pressure status by pressing "No".

When the reset is finished, a confirmation message is displayed on the screen.

# MY DRIVING

## "My driving" menu

**i** Certain features are only available while the vehicle is stationary.

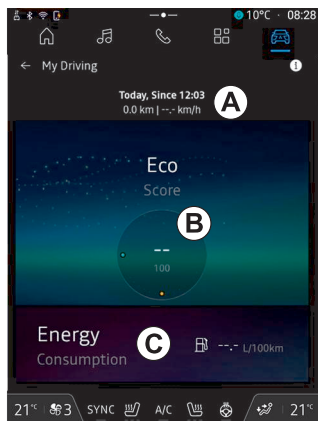

From the "Vehicle" Menu , press "My driving" to access the following information and functions:

- start date, distance travelled and average speed of the current journey **A**;
- "Eco score" **B**;
- "Energy consumption" **C**.

You can also access it from the "Eco score" widget in the "Home page" or

"Navigation" Menu .

From the "Information" icon , you can access information related to the "My driving".

### Note:

- the information that can be accessed via the "My driving" menu may vary according to your vehicle equipment level.
- the data displayed is automatically reset when the engine has been shut down for at least two hours or when changing "Profile".

## "Safety score"

(depending on equipment and country)

## "Journey in progress"

From the "Current journey" **E**, you can view your driving safety data since your departure and along the current journey.

At the beginning of the journey, the scores are in the process of being initialised and are therefore not displayed.

Scores are associated with profiles. If you change "Profile", the journey scores are reset.

By selecting the "i" information icon, you can access information related to the "Safety score".

**Note:** the data displayed is calculated from the last vehicle data reset, either automatically after the vehicle has not been used for two hours or when the "Profile" is changed.

### Overall score 1

This data allows you to know your overall score (from 0 to 100) on the current journey.

The colour linked to the overall score describes your driving performance in relation to the criteria measured:

- green gauge: your score is good, your driving performance is satisfactory in relation to these criteria;
- yellow gauge: your score is average; your driving is not always satisfactory in relation to these criteria;
- orange gauge: your score is low; your driving is sometimes risky;
- red gauge: your score is too low, your driving is risky.

### Calculation of sub-scores 2

Sub-scores are assessments of your driving safety on the current route based on the following criteria:

- "Safe speed" assesses the difference between your measured speed and the recommended speed;

## MY DRIVING

- "Following distance" assesses the distance between your vehicle and the vehicle in front;
- "Trajectory", assesses lateral and longitudinal accelerations, as well as the use of the turn signal in the event of a lane change;
- ...

**Note:** for more information on defining the different sub-scores, tap one of them.

### Driving Advice and Safety 3

Using your sub-scores, this information offers you a safe driving rating to help you drive more safely.

To access additional advice, press "Advice".

### "History F"

From the "History" view mode **F**, you can access the following history logs:

- your journey scores for the current month **4**;
- your monthly score **5**;
- your safety rating for the current month **6**;
- introduces the tip for the month **7**.

This information is provided according to the scores over the current month.

Advice is provided based on the lowest monthly scores.

Access to the history is linked to the Profile.

### "Eco score"

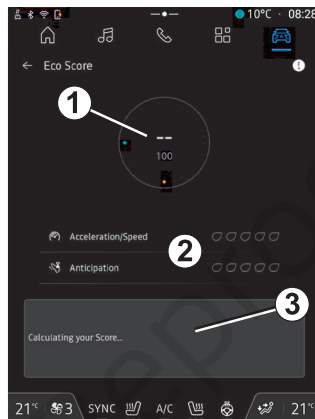

From the "Eco score" view mode **B**, you can view the your driving behaviour with regard to energy saving since your departure on your current journey.

**Note:** the data displayed is calculated from the last vehicle data reset, either automatically after the vehicle has not been used for two hours or when the "Profile" is changed.

Using the "Information" icon **i**, you can access information related to the "Eco score".

### Overall score 1

This data allows you to know your overall score (from 0 to 100) on the current journey:

- score between 76 and 100: "Congratulations, you are an Eco driver";
- score between 51 and 75: "You have a normal driving style";
- score between 0 and 50: "You have a dynamic driving style".

The overall score is calculated from the sub-scores.

### Calculation of sub-scores 2

Sub-scores are assessments of your driving behaviour on the current route based on the following criteria:

- "Acceleration" assesses your behaviour in relation to acceleration and speed;
  - "Anticipation", assesses your ability to anticipate and avoid hard braking;
  - "Gear change" assesses your behaviour regarding gear changes in relation to the gear change indicator displayed on the instrument panel;
- Note:** this assessment is only available with manual gearboxes.

- ...

### Driving advice and style 3

## MY DRIVING

Using your sub-scores, this information offers you a driving style rating to help you drive more efficiently.

To access additional advice, press "Advice".

### « Energy consumption »

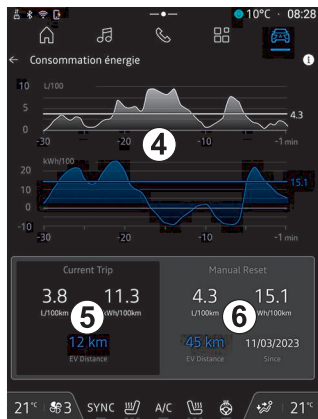

From the "Power consumption" view mode **C**, you can view the following energy consumption data for your driving:

- current journey data **4**;
- data since the last manual reset **5**;
- history of average consumption **6**.

Using the "Information" icon **i**, you can access information related to "Energy consumption".

### Current journey data **4**

Depending on the version, the following data may be available:

- "Average consumption";
- ...

**Note:** the data displayed is calculated from the last "Eco score" data reset, automatically after the vehicle has not been used for two hours and when changing "Profile".

### Data since last reset **5**

Depending on the version, the following data may be available:

- "Average consumption";
- date of the last reset;
- ...

**Note:** the displayed data is reset along with the instrument panel data.

### Evolution of average consumption **6**

A graph shows the evolution of your average consumption per minute, over the last thirty minutes of the journey.

The row and associated value correspond to the average consumption since the last manual reset.

**Note:** the chart data is reset along with the data since the last manual reset.

## EMERGENCY CALL

If the vehicle is equipped with it, the emergency call system enables automatic or manual calling of the emergency services in the event of an accident or illness, in order to reduce the emergency response time.

When the emergency services have been called, the audio source/radio sound volume is automatically muted.

Use of the "Emergency call" function deactivates some multimedia system commands and menus for almost one hour in order to give priority to emergency service response telephone calls.

Please refer to the vehicle user manual for further information.

6



This system is optional equipment and may not be fitted to all models

## USER SETTINGS

### "Vehicle" menu



For safety reasons, carry out any adjustments while the vehicle is stationary.

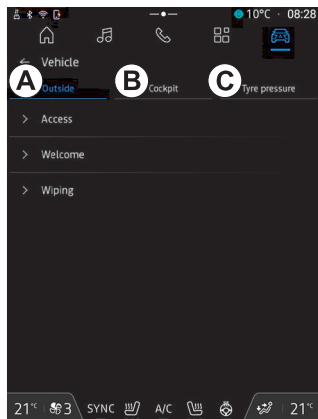

From the "Vehicle" Menu , select the "Vehicle" menu.

From this menu you can access the following tabs:

- "Outside" **A**;
- "Cockpit" **B**;
- "Tyre pressure" **C**.

**Note:** the availability of settings may vary according to the equipment level.

### "Outside" **A**

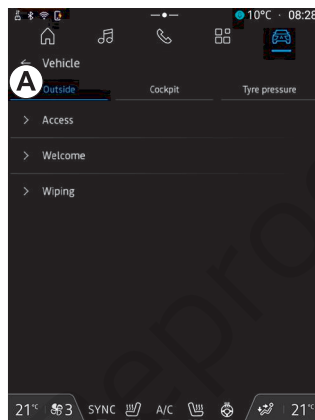

#### « Access »

Use this menu to activate/deactivate the following options:

- « Auto door lock while driving » ;
- « Hands-free lock/unlock » :
- « Silent mode » ;

**Note:** some options are available only if the previous functions are activated.

- ...

#### « Welcome »

Use this menu to activate/deactivate the following options:

- « External lighting sequence » ;
- « Internal sequence sound » ;
- « Automatic mirrors' unfolding » ;
- « Internal light function » ;
- ...

#### « Driving lights »

Use this menu to activate/deactivate the following options:

- "Adaptive lighting";
- « Traffic side selection » :
  - « Left » ;
  - « Right ».

- ...

**Note:** some options are available only if the previous functions are activated.

#### « Wiping »

Use this menu to activate/deactivate the following options:

- "Rear wiper when in reverse gear": the rear screen wiper is activated when reverse gear is engaged;

**Note:** this function only operates if the front windscreen wipers are activated.

- « Automatic front wiper » ;
- ...

## USER SETTINGS

### "Cockpit" B

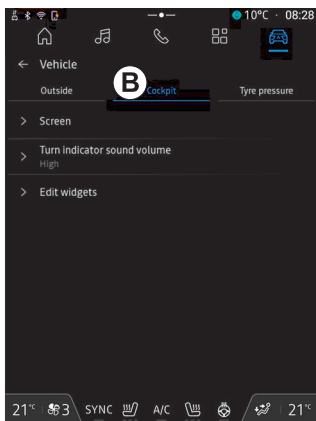

7

#### « Display »

Use this menu to activate/deactivate the "Automatic brightness" (depending on equipment) and to adjust the following options:

- « Multimedia: daytime brightness » ;
- « Multimedia: nighttime brightness » ;
- « Cockpit brightness » ;
- ...

**Note:** some options are available only if the previous functions are activated.

#### « Turn indicator sound volume »

Use this menu to adjust the volume of the indicators in the passenger compartment:

- « Low » ;
- « Middle » ;
- « High » .

#### « Favourite button on the steering wheel »

Use this menu to configure the "Favourite button on the steering wheel" by allocating its function as one of the following:

- « Climate » ;
- « Eco mode » ;
- « 360° Camera » ;
- ...

**Note:** the available options may vary according to the equipment level.

#### « Edit widgets »

From this menu you can modify the "Home screen" or "Navigation" Menu

widgets  available depending on your vehicle's equipment:

- « Google Assistant » ;
- « 360° Camera » ;
- « Date and time » ;
- « Tyre pressure » ;
- « Audio » ;

– ...

### "Tyre pressure" C

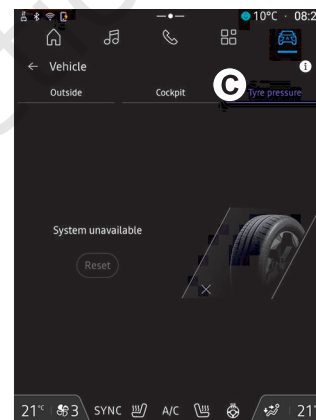

Use this menu to check the vehicle tyre pressure status and to carry out a reset.

For more information on tyre pressure, please see:

- the section on "Tyre pressure" → 90;
- your vehicle user manual.

# USER SETTINGS

## Menu "Profile"

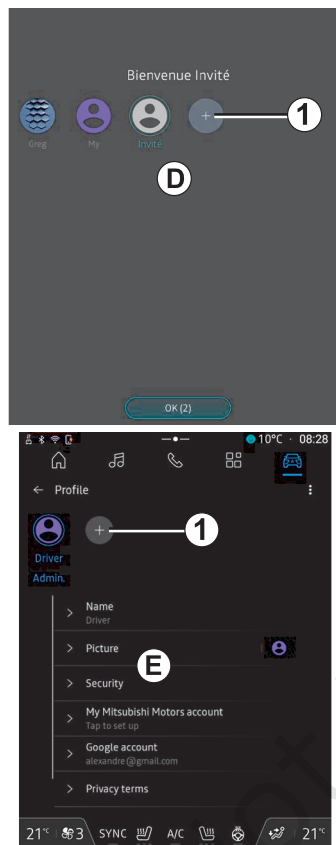

When the multimedia system is started, at **D**, you can choose or add a

user profile to apply to the system and to the vehicle.

Select the desired user profile.

**Note:** it is only possible to change the profile while the vehicle is stationary.

You can access the "Profile" **E** menu from the notifications centre at any time by pressing the image on your profile.

### Features linked to user profile

The following settings are stored in the user profile:

- system language;
- Google® account;
- settings for the terms of use of personal data;
- display settings;
- Drive Mode settings;
- ambient lighting settings;
- driver's seat settings;
- door mirror settings;
- audio settings;
- navigation settings;
- navigation history;
- navigation favourites;
- ...

**Note:** the first profile created will be the default Administrator profile. Some settings are only available via the Administrator profile.

## Add a "Profile"

To add a new "Profile", press **1** then follow the instructions displayed on the multimedia screen.

**Note:**

- you can add up to five "Profile";
- every time you create a new "Profile" a configuration is required: please see the section on "Activating services" → 11.

## "Profile" settings



To better protect your personal data, we recommend that you lock your profile.

7

## USER SETTINGS

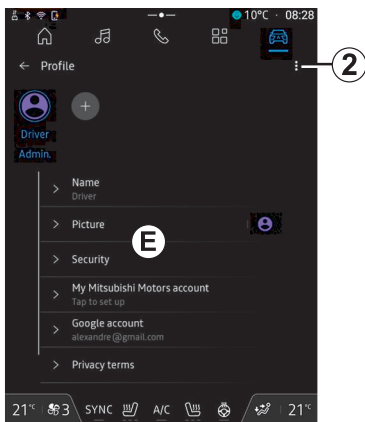

From **2** you can access the following functions:

- « Manage profiles » ;
- « Manage accounts » ;
- « Delete profile » ;
- « Guest profile » .

From the menu zone **E** you can modify the following:

- « Name » ;
- « Picture » ;
- « Security » :
  - "Select locking mode";
  - "Delete ID";
  - "Unlock profile with phone".

You can use this function to unlock your "Profile" using your smartphone, if present in your vehicle.

For further information, please refer to the section on "System settings" → **103**.

- "Google® account";
- « Privacy terms » ;
- « Privacy settings » :
  - « Accept all » ;
  - « Refuse all » ;
- « Customise » .

For further information, please refer to the "Activating services" section → **11**.

- ...

### Profile « Guest »

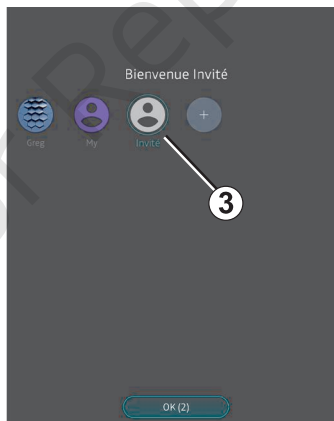

The "Guest" (GUEST) profile can be used to access some of the multimedia system functions like a user profile.

To access it, press **2** then "Guest profile" or **3** during start-up.

The "Guest" profile is reset every time the system restarts and the settings are not stored.

# SYSTEM SETTINGS

## "Settings" menu



For safety reasons, carry out any adjustments while the vehicle is stationary.

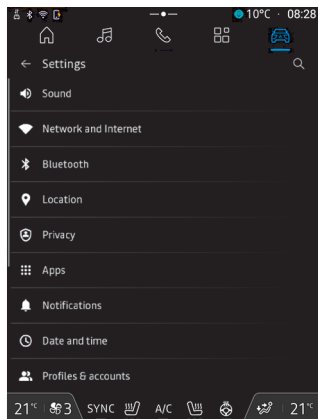

From the "Vehicle" Menu , press "Settings".

You can also access the "Settings" menu from the Notifications centre by pressing the "Settings" icon.

**Note:**

- the availability of settings may vary according to the equipment level;
- some settings are available while the vehicle is stationary.

This menu enables you to adjust the following settings:

- « Sound » ;
- "Network and Internet";
- « Bluetooth® » ;
- "Location";
- "Confidentiality";
- "Apps";
- "Notifications";
- « Date and time » ;
- "Profiles and Accounts";
- « Security » ;
- « System » ;
- « Update & assistant » ;
- « Google® » ;
- ...

### « Sound »

This menu can be used to set and adjust the following volume settings:

- « Media volume » ;
- "Incoming call volume";
- "Telephone ringtone volume";
- "Notifications volume";
- "Navigation volume";
- « Assistant volume » ;
- "Phone ringtone";
- ...

## "Network and Internet"



When you use connection sharing on your phone, you are using your phone's Internet connection via the WIFI connection (subject to charges and limitations imposed by your mobile operator).

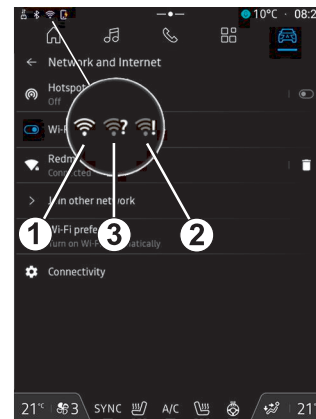

7

## SYSTEM SETTINGS

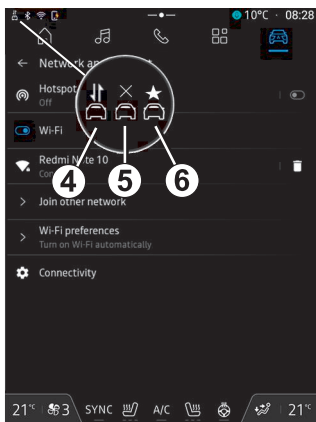

7

This menu can be used to configure the following internet networks:

- "Access point":
  - enable/disable "Access point";
  - access point details;
  - activate/deactivate the access point automatically;
  - ...
- « WiFi » :
  - activate/deactivate the "WiFi" on the multimedia system for using a remote internet access point;
  - view available networks;
  - "Add a network".
- "WiFi settings"
- "Connectivity" provides information on:

- connectivity data and status;
- on "Network type";
- system ID;
- ...

When you activate the multimedia system "WiFi", you are notified of its status via the icon on the status bar:

- **1** "WiFi" activated and connected to a network without a limited connection;
- **2** "WiFi" activated and connected to a network but without any internet access or with a limited connection;
- **3** "WiFi" activated but not connected to a network.

**Note:** if "WiFi" is deactivated, no WiFi icon will appear on the status bar.

You can also see information on the data sharing status by pressing the icon on the status bar:

- **4** "Accept all", share all data;
- **5** "Refuse all": does not share any of the data;
- **6** "Customise", share only the data that you have authorised.

For more information on data sharing, please refer to the section on "Activating services" ➔ 11.

**Note:** if you refuse to share data, no icon will appear in the status bar.

### « Bluetooth® »

This menu can be used to adjust the multimedia system Bluetooth® functions:

- activate/deactivate the multimedia system "Bluetooth®";
- "Set the telephone service data";
- « Pair new device ».

### "Location"

This menu can be used to adjust the vehicle location settings:

- "Recent location requests";
- "App permissions".

### « Applications »

Use this menu to configure the multimedia system applications:

- "Display all apps";
- "Default apps";
- "App permissions";
- "Specific access rights granted to apps";

### "Notifications"

Use this menu to configure the multimedia system notifications:

- « Proactive recommendations ».

## SYSTEM SETTINGS

### « Date and time »

This menu can be used to adjust the date and time on the multimedia system:

- "Set the time zone automatically";
- "Set the time zone" (manually);
- "Use the 24-hour format".

### "Profiles and accounts"

Gives access to the multimedia system profile menu.

### « Security »

This menu can be used to adjust the multimedia system security settings:

- "Lock the profile";
- "Delete ID";
- "Security update";
- "Unlock profile with phone".

### « System »

This menu can be used to adjust the multimedia system settings:

- "Language and input";
- "Units" (km/h or mph);

**Note:** the speedometer and some of the distance information displayed on the instrument panel are converted. To return to the previous mode, repeat the same operation.

- "Storage":

- "Music and audio";
  - "Other apps";
  - "Files";
  - « System ».
- "About";
  - "Legal information";
  - "Resetting options";
  - ...

### « Update & assistant »

This menu allows you to consult and/or configure the following functions:

- "Proactive suggestions";  
For more information, please refer to the "Notifications" → **102** section.
- « My trusted device » ;
- « Vehicle update » ;  
For more information, please refer to the "Update" → **104** section.
- ...

### « Google® »

This menu can be used to adjust the Google® services:

- « Google Assistant » ;
- "Send comments to Google®".

# NOTIFICATIONS

## Notification centre



For safety reasons, carry out these operations when the vehicle is stationary.



The Notifications centre provides notifications during driving as well as certain functions, suggestions and settings such as:

- access to the user "Profile" **3**;
  - the status of services **B**:
    - activate/deactivate the WIFI;
    - activate/deactivate the Bluetooth®;
    - mute/unmute the sound.
  - the "Settings"  **4**;
  - shortcuts to the vehicle equipment and screen brightness controls **C**;
- Note:** the availability of shortcuts and command types depends on the equipment and cannot be modified.

- the list of notifications received **D**;
- recently used apps;
- ...

By pressing button **1** or by quickly swiping the multimedia screen vertically from zone **A** towards the centre of the screen, you can access the Notifications centre in order to view the notifications and available functions.

When an unread notification is available, a dot **2** will appear in the middle of button **1**.

By pressing **2**, you will automatically open the Notifications centre and be able to read any unread notifications, then the symbol will disappear.

Once the Notifications centre is open, select a notification from the list **D** to access it.

You can delete the notification by performing a quick horizontal swipe on the screen.

To delete all notifications, press button **5**.

**Note:** some notifications will need a required action to be completed in order to be deleted from the notification centre.

To exit the notification centre, press **1** or swipe up quickly from the bottom of the screen towards the centre of the screen.

## NOTIFICATIONS

### Notification settings

From the "Settings" icon  or the

"Vehicle" Menu  , access the "Settings" menu, then the "Apps and notifications" menu.

Use this menu to configure the multimedia system notifications.

For more information on the "Apps and notifications" menu, please refer to the "System settings" section ➔ 99.

### « Proactive suggestions »

The "Proactive suggestions" function informs you via a notification that a "Drive Mode" mode more adapted to your current driving is available.

The multimedia system suggests the following options:

- « Yes » ;
- « No » ;
- « Always no » .

From the "Settings" icon  or

the "Vehicle" Menu  , access the "Settings" menu, then the "Updates and Assistant" menu, followed by "Proactive suggestions".

This menu can be used to configure the proactive recommendation notifications on the multimedia system.

**Note:** you must enable data sharing in order to use the "Proactive suggestions" function. For more information please refer to the section on "Activating services" ➔ 11.

## UPDATE

### "Vehicle update" menu

 Some update installations may render your vehicle temporarily unavailable for use. If so, please refer to the indications displayed on the screen.

 The vehicle must be immobilised, stationary and the ignition switched off. In some cases, you will not be able to start your vehicle for the duration indicated by the multimedia system.



For safety reasons, carry out these operations when the vehicle is stationary.



Before starting the installation, park the vehicle far away from traffic and apply the parking brake.

From the "Vehicle" Menu , access the "Vehicle" menu, "Settings", "Update & assistant", then select "Vehicle update".

This menu can be used to display different types of information and to update your vehicle, for example:

- multimedia equipment;
- driving aids;
- ...

The system may offer updates automatically. You can also check for updates manually, depending on your vehicle's connectivity.

### The "Vehicle update" screen

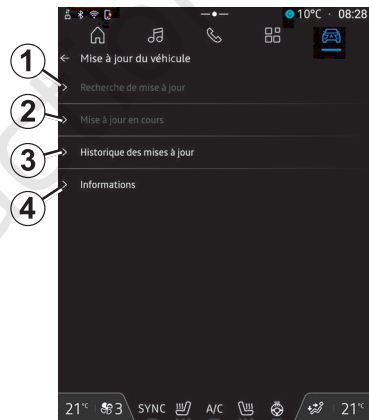

1. « Checking for update ».
2. « Update in progress ».
3. « Update history ».
4. « Information ».

#### Note:

- you will be notified via Notifications if an update is available. Please refer to section on "Notifications" → 102;
- if an update is available, the download will start automatically;
- updates can only be searched for and downloaded if your vehicle is located in a geographical area covered by a mobile network. For more information, refer to the section on "System settings" → 101;

## UPDATE

- if the update is not available in the country where the vehicle is located, the "Checking for update" and "Update in progress" menus are unavailable.

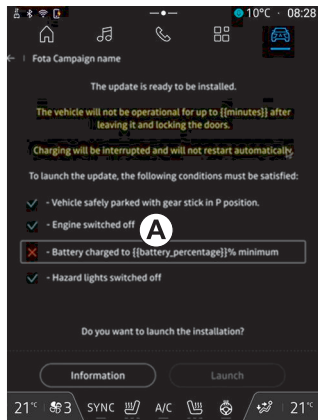

When an update installation is ready, your agreement and confirmation will be requested in order to complete the installation.

To start the update, all the conditions displayed on the multimedia system screen **A** must be met.

Follow the instructions shown on the multimedia system screen.

### Note:

- depending on the update, the screens may be switched off;
- some installations require you to exit and lock your vehicle.

Upon restarting of the multimedia system, a message is displayed to confirm that the update has been successfully completed.

In the event of an error, please refer to the section on "Operating faults" → 106.

### « Checking for update » 1

You can also search for updates directly by pressing "Checking for update" 1.

After searching the multimedia system, you can access the next update if available.

Follow the instructions shown on the multimedia system screen.

Updating may take several days but during this time you will be able to use your vehicle normally.

### « Update in progress » 2

This menu is accessible when an update is available.

When an update is in progress, press

the "Information" icon **i** to access the update content information.

**Note:** when a "Update in progress" is unavailable, the "Checking for update" is not accessible.

### « Update history » 3

This menu can be used to view the update history and status.

To find information on previous updates, select an update.

### « Information » 4

This menu allows you to access information related to updates, to view the "VIN" (vehicle identification number), etc.



Updating will render your vehicle temporarily unavailable and the charging function is inhibited during installation of the update.

## OPERATING FAULTS

### System

System		
Description	Causes	Solutions
No image is displayed.	The screen is on standby.	Ensure that the screen is not on standby.
The screen is frozen.	The system memory is saturated.	Restart the system by pressing and holding: – the multimedia stop/start button (press and hold until the system restarts); or – the "Mode" button and the "Source" button on the left-hand side of the steering column control (press and hold until the system restarts).
The camera is displayed on the screen incorrectly.	The camera is covered in dirt that obscures the lens.	Check that there is no mud or dirt on the camera.
No sound can be heard.	The volume is set to minimum or pause.	Increase the volume or deactivate pause.
No sound comes from the left, right, front or rear speakers.	The Balance or fader settings are incorrect.	Adjust the sound Balance or fader correctly.
The connected services in my Audio unit do not work.	Poor multimedia system/telephone Internet network reception. Synchronisation problem with the service provider	Move the vehicle and the phone to an area covered by the Internet network.
The services or applications are not operating.	The subscription is suspended. The multimedia system's internet connection is no longer available.	Check the status of your subscription on the portal of the internet provider

## OPERATING FAULTS

System		
		Use your phone's "Access point and connection sharing" function to access an internet connection (see the "System settings" section ➔ 99).

## OPERATING FAULTS

### Navigation

Navigation		
Description	Causes	Solutions
The vehicle position on the screen does not match its actual location or the GPS warning light on the screen remains grey or yellow.	Incorrect positioning of the vehicle caused by GPS reception.	Move the vehicle until reception of the GPS signal is improved.
Traffic flow information is not displayed on the screen.	Guidance has not been activated. Connected services are not activated.	Ensure guidance is activated. Select a destination and begin the guidance. Check that the connected services are activated and activate data collection.
some items on the menu are not available.	Depending on the current command, some items will be unavailable. Some functions are not available while the vehicle is moving.	Stop the vehicle.
Voice guidance is unavailable.	Voice guidance or guidance is deactivated.	Increase the volume. Ensure voice guidance is activated. Check that guidance is in progress.
The suggested route does not start or end at the required destination.	The destination is not yet recognised by the system.	Enter a road near to the required destination.

## OPERATING FAULTS

### Phone

Phone		
Description	Causes	Solutions
The phone does not appear in the list of available phones.	The system is not communicating with the phone.	Make sure that your phone's Bluetooth® is activated. If the phone still doesn't appear, select the multimedia system from the list of devices on your phone.
The phone appears in the list of paired phones, but pairing fails.	The pairing code has not been confirmed.	Confirm the code on the multimedia system and on the phone.
No sounds or ringtone can be heard.	The mobile phone is not connected to the system. The volume is set to minimum or pause.	Ensure that the mobile phone is connected to the system. Increase the volume or deactivate pause.
Impossible to make a call.	The mobile phone is not connected to the system. The phone keypad has been locked.	Ensure that the mobile phone is connected to the system. Unlock the phone keypad.
Wireless CarPlay™ or Android Auto™ replication is not operating.	The telephone is not connected or is not compatible with the system.	Check the compatibility of the telephone with these applications. Check that the telephone is properly connected to the system.  Environmental interference such as cellular towers, other vehicles, bridges or other infrastructure may cause disconnection of the wireless CarPlay™ or Android Auto™.

## OPERATING FAULTS

### Voice recognition

Voice recognition		
Description	Causes	Solutions
The system does not recognise the voice command stated.	<p>The voice command has not been recognised.</p> <p>The voice recognition time delay has expired.</p> <p>The voice recognition cannot operate properly due to a noisy environment.</p>	<p>Check that voice control is available (refer to the information on "Using voice recognition"). → 22). Speak within the voice recognition time delay.</p> <p>Speak in a quiet environment.</p>

## OPERATING FAULTS

### Update

Update		
Description	Causes	Solutions
Downloading the new SW (software) takes a very long time.	Poor reception of the Internet network. The download requires a minimum driving time.	Move the vehicle to an area covered by the Internet network. Carry out additional driving phases.
The update completion is never requested.	The vehicle is not secured.	Check that the vehicle is properly stopped (parking brake applied).
Screens are off, loss of sound, loss of some functions during the update.	The update is in progress.	Wait for updating to end.
The request to complete the update does not appear.	No response in the month following the beginning of the update.	The server will restart the operation later. You can manually check if the update is still available.
The update was not completed.	Updating system internal error: the other functions are not affected.	Consult an approved Dealer. Wait until the update is complete before performing a direct current charge. For more information on the warning lights, please refer to the vehicle user manual.
The update failed to complete due to an error and the <b>STOP</b> warning light is displayed.	Critical error.	The vehicle must not be restarted. Call an approved dealer. For more information on the warning lights, please refer to the vehicle user manual.

## OPERATING FAULTS

Update		
The update failed to complete due to an error and the  warning light is displayed.	Error during updating (non-critical).	Contact an approved dealer to resolve the issue. For more information on the warning lights, please refer to the vehicle user manual.

# ALPHABETICAL INDEX

## Symbols

360° camera, 83

## A

Address: home, 32

Address: work, 32

Adjust the sound volume, 64

Android Auto™, Carplay™, 22, 48, 67

Answer a call, 58

## B

Bluetooth®, 48

Buttons, 9, 15

## C

Call log, 60

Call waiting, 57

Configuration of the multimedia system, 97

Connected services, 11

Connecting a telephone, 54

Controls, 9, 15

Customising the settings, 20, 20, 99

## D

Dial number, 57, 61

Disconnect a phone, 54

Display 2D/3D: modes 2D/3D, 28

Display on the instrument panel, 29

drive USB, 48

Driving aids, 7

## E

ECO driving, 91

Emergency call, 94

End a call, 57, 59

Energy saving, 92

Enter a number using the keypad 61

## F

Fuel consumption, 93

Fuel economy, 93

## G

Google Assistance™, 22, 56

Google Maps™, 22, 28, 32, 38

Google Play™, 71

Guidance: map, 28

## H

Hands-free parking, 81

## M

Map: display, 28

## ALPHABETICAL INDEX

Map: map icons, 28  
Map: settings, 28  
Menu: home page, 20  
Mobile phonebook, 59  
Multimedia equipment, 5  
Multimedia screen, 5  
Multi-view camera, 83  
Music, 48

### N

Navigation: entering a destination, 32  
Navigation: navigation history, 32  
Navigation: navigation settings, 38  
Navigation system, 28  
Notifications: suggestions and notifications, 17, 102

### O

Operating faults, 106

### P

Pair a phone, 53  
Parking distance control, 79  
Personal data: saving, 11, 53, 59  
Phone settings: phone ringtone, 64  
Point of Interest, 32

### R

Radio: automatic storage of stations, 44

Radio: station pretuning, 44  
Radio select a station: listen to the radio, 44  
Receiving a call, 57  
Reject a call, 57  
Reversing camera, 84  
Reversing camera activation: guide lines, 82  
Reversing camera settings: image settings, 82

### S

Screen: menu, 5  
Screen: standby, 19  
Screen controls, 9  
Settings, 64, 95  
Settings: customisation, 98  
Settings: navigation, 38  
smartphone replication, 22, 6  
SMS, 62  
SMS: reading SMS, 62  
SMS: receiving SMS, 62  
Soft buttons, 5  
Source, 48  
Source: audio, 42  
Start the multimedia system, 19  
Steering wheel controls and panels, 9  
Switching off, 19  
System: updating, 104

## ALPHABETICAL INDEX

### T

Tyre pressure, [90](#)

### U

Unpairing a telephone, [53](#)

### V

Vehicle ambience: customisation, [88](#)

Vehicle customisation settings, [95](#)

Voice controls, [22](#)

Voice recognition, [22](#)

### W

Wifi, [68](#), [69](#), [69](#), [72](#), [103](#)

Wireless charger: induction charging, [65](#)

Not For Reproduction



# **SMARTPHONE-LINK DISPLAY AUDIO (SDA)**

---

Owner's Manual

Printed in France  
MITSUBISHI MOTORS  
ABN 53 007 870 395